



EMC TEST REPORT

Authorized under **Declaration of Conformity**

According to

EN 61000-6-3 : 2007+A1:2011	EN 61000-6-1 : 2007
EN 61000-3-2 : 2014	IEC 61000-4-2 : 2008
EN 61000-3-3 : 2013	IEC 61000-4-3 : 2006+A1:2007+A:2010
	IEC 61000-4-4 : 2012
	IEC 61000-4-5 : 2014
	IEC 61000-4-6 : 2008
	IEC 61000-4-8 : 2009
	IEC 61000-4-11 : 2004

Applicant	: NANTONG SCHMIDT OPTO-ELECTRICAL TECHNOLOGY CO.,LTD
Address	: No.399,zhongshan West Road, Rugao City, Jiangsu, CHINA
Equipment	: ASTRO FI
Model No.	: Astro Fi 90; Astro Fi 102; Astro Fi 130; Astro Fi 5; Astro Fi 6

I HEREBY CERTIFY THAT :

The sample was received on Jun 22, 2016 and the testing was carried out on Jun 24, 2016 at CerpPASS Technology Corp. The test result refers exclusively to the test presented test model / sample. Without written approval of CerpPASS Technology Corp., the test report shall not be reproduced except in full.



EMC TEST REPORT

Issued by:

Cerpass Technology (Suzhou) Co.,Ltd

No.66,Tangzhuang Road, Suzhou Industrial Park, Jiangsu 215006, China

Tel:86-512-6917-5888

Fax:86-512-6917-5666

The test record, data evaluation & Equipment Under Test configurations represented herein are true and accurate accounts of the measurements of the samples EMC characteristics under the conditions specified in this report.

The above equipment was tested by Cerpass Technology Corp. for compliance with the requirements of technical standards specified above under the EMC Directive **2014/30/EU**. The results of testing in this report apply only to the product/system, which was tested. Other similar equipment will not necessarily produce the same results due to production tolerance and measurement uncertainties

Approved by:

Miro Chueh
EMC/RF B.U. Manager

Laboratory Accreditation:

Cerpass Technology Corporation

TAF LAB Code:	1439
----------------------	-------------

Cerpass Technology(SuZhou) Co., Ltd.

CNAS LAB Code:	L5515
-----------------------	--------------



Contents

1. Summary of Test Procedure and Test Results	6
2. Immunity Testing Performance Criteria Definition	7
3. Test Configuration of Equipment under Test	8
3.1. Manufacturer	8
3.2. Feature of Equipment under Test	8
3.3. Test Software and Test Mode	8
3.4. Description of Test System	9
3.5. General Information of Test	10
3.6. Measurement Uncertainty	11
4. Test of Conducted Emission	13
4.1. Test Limit	13
4.2. Test Procedures	14
4.3. Typical Test Setup	14
4.4. Measurement equipment	15
4.5. Test Result and Data	15
5. Test of Radiated Emission	16
5.1. Test Limit	16
5.2. Test Procedures	17
5.3. Typical test Setup	18
5.4. Measurement equipment	19
5.5. Test Result and Data (30MHz ~ 1000MHz)	20
5.6. Test Result and Data (1GHz ~ 6GHz)	22
5.7. Test Photographs (30MHz ~ 1000MHz)	24
5.8. Test Photographs (1GHz ~ 6GHz)	25
6. Harmonics Test	26
6.1. Limits Of Harmonics Current Measurement	26
6.2. Measurement equipment	27
6.3. Test Result and Data	27
7. Voltage Fluctuations Test	28
7.1. Test Procedure	28
7.2. Measurement equipment	28
7.3. Test Result and Data	28
8. Electrostatic Discharge Immunity Test	29
8.1. Test Procedure	29
8.2. Test Setup for Tests Performed in Laboratory	30
8.3. Test Severity Levels	31
8.4. Measurement equipment	31
8.5. Test Result and Data	32
8.6. Test Photographs	33
9. Radio Frequency electromagnetic field immunity test	37
9.1. Test Procedure	37
9.2. Test Severity Levels	37



9.3. Measurement equipment 38

9.4. Test Result and Data 39

9.5. Test Photographs 40

10. Electrical Fast Transient/ Burst Immunity Test 41

10.1. Test Procedure 41

10.2. Test Severity Levels 42

10.3. Measurement equipment 42

10.4. Test Result and Data 42

11. Surge Immunity Test 43

11.1. Test Procedure 43

11.2. Test Severity Level 44

11.3. Measurement equipment 44

11.4. Test Result and Data 44

12. Conduction Disturbances induced by Radio-Frequency Fields 45

12.1. Test Procedure 45

12.2. Test Severity Levels 46

12.3. Measurement equipment 46

12.4. Test Result and Data 46

13. Power Frequency Magnetic Field Immunity Tests 47

13.1. Test Setup 47

13.2. Test Severity Levels 47

13.3. Measurement equipment 47

13.4. Test Result and Data 48

13.5. Test Photographs 49

14. Voltage Dips and Voltage Interruptions Immunity Test Setup 50

14.1. Test Conditions 50

14.2. Measurement equipment 50

14.3. Test Result and Data 50

15. Photographs of EUT 51



History of this test report

ORIGINAL.

Additional attachment as following record:

Report No	Version	Date	Description
SECE1606125	Rev 01	Jun 27,2016	Initial Issue
SECA1606125-B	Rev 02	Nov 05,2018	Second Issue(Add model name: Astro Fi 6)

**1. Summary of Test Procedure and Test Results**

EMISSION 【EN 61000-6-3:2007+A1:2011】			
Standard	Item	Result	Remarks
EN 61000-6-3:2007+A1:2011	Conducted (Power Port)	N/A	N/A
	Conducted (Telecom port)	N/A	N/A
	Radiated	PASS	Meets Class B Limit Minimum passing margin(Peak) is -7.44 dB at 30.0000MHz
EN 61000-3-2: 2014	Harmonic current emissions	N/A	N/A
EN 61000-3-3 : 2013	Voltage fluctuations & flicker	N/A	N/A

IMMUNITY 【EN 61000-6-1 : 2007】			
Standard	Item	Result	Remarks
IEC 61000-4-2: 2008	ESD	PASS	Meets the requirements of Performance Criterion B
IEC 61000-4-3: 2006+A1:2007+A2:2010	RS	PASS	Meets the requirements of Performance Criterion A
IEC 61000-4-4: 2012	EFT	N/A	N/A
IEC 61000-4-5:2014	Surge	N/A	N/A
IEC 61000-4-6:2008	CS	N/A	N/A
IEC 61000-4-8:2009	PFMF	PASS	Meets the requirements of Performance Criterion A
IEC 61000-4-11:2004	Voltage dips & voltage variations	N/A	N/A



2. Immunity Testing Performance Criteria Definition

Criteria A:	<p>The apparatus shell continues to operate as intended without operator intervention. No degradation of performance or loss of function is allowed below a performance level specified by the manufacturer, when the apparatus is used as intended. The performance level may be replaced by a permissible loss of performance. If the manufacturer does not specify the minimum performance level or the permissible performance loss, then either of these may be derived from the product description and documentation, and by what the user may reasonably expect from the equipment if used as intended.</p>
Criteria B:	<p>After test, the apparatus shell continues to operate as intended without operator intervention. No degradation of performance or loss of function is allowed, after the application of the phenomenon below a performance level specified by the manufacturer, when the apparatus is used as intended. The performance level may be replaced by a permissible loss of performance.</p> <p>During the test, degradation of performance is however allowed. However, no change of operating state if stored data is allowed to persist after the test. If the manufacturer does not specify the minimum performance level or the permissible performance loss, then either of these may be derived from the product description and documentation, and by what the user may reasonably expect from the equipment if used as intended.</p>
Criteria C:	<p>Temporary loss of function is allowed, provided the functions is self-recoverable or can be restored by the operation of controls by the user in accordance with the manufacturer instructions.</p> <p>Functions, and/or information stored in non-volatile memory, or protected by a battery backup, shall not be lost.</p>



3. Test Configuration of Equipment under Test

3.1. Manufacturer

3.2. Feature of Equipment under Test

ASTRO FI	Model No:	Astro Fi 90; Astro Fi 102; Astro Fi 130; Astro Fi 5; Astro Fi 6
Remark	The add model name and original name are identical except the model name and add the Six inches of lens.	

WLAN	ROVING NETWORKS/RN-171
Operation Frequency	2412-2472MHz
RF Output Power	WLAN 802.11b: 15.24 dBm WLAN 802.11g: 19.59 dBm
Antenna Type	Antenna 1: Dipole antenna Antenna 2: Dipole antenna Antenna 3: PCB antenna Antenna 4: Wired antenna Antenna 5: Chip antenna
Antenna Gain	Antenna 1: 2.2 dBi Antenna 2: 1 dBi Antenna 3: 0 dBi Antenna 4: 0 dBi Antenna 5: 0 dBi

3.3. Test Software and Test Mode

Test Manner

- a During testing, the interface cables and equipment positions were varied according to Europe Standard.
- a. During the test, connect the iPhone and EUT, make the EUT at the test mode.

The pre-test modes

Mode 1: Normal Operation

The worse case was selected as the final test mode and record in the report

Mode 1: Normal Operation



3.4. Description of Test System

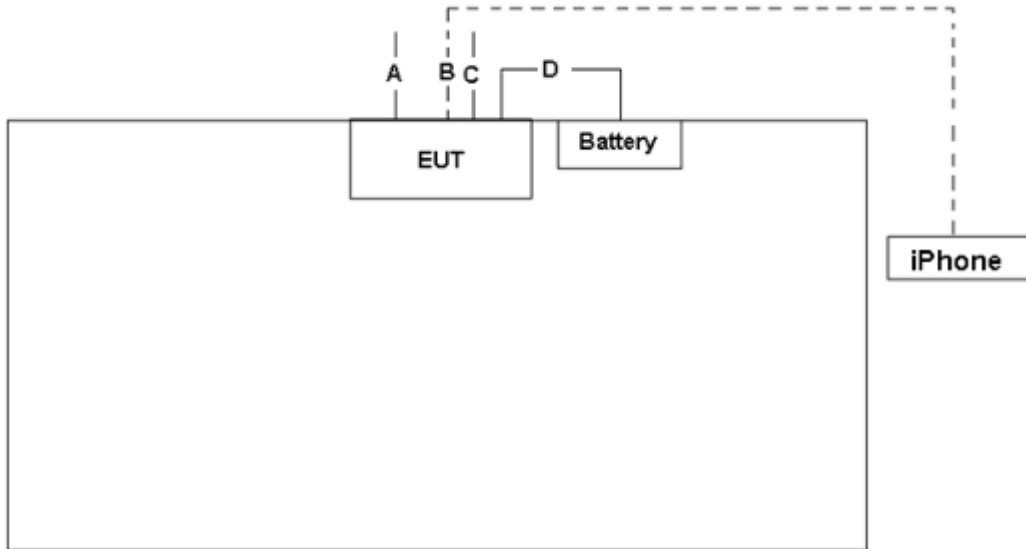

No	Device	Manufacturer	Model No.	Description
1	iPhone	APPLE	iPhone 5S	N/A

Use Cable:

Item	Cable	Quantity	Description
A	Telephone Cable	1	Non-Shielded, 1.2m
C	Telephone Cable	1	Non-Shielded, 1.2m
D	DC Cable	1	Non-Shielded, 1.2m

**3.5. General Information of Test**

<input type="checkbox"/>	Test Site	Cerpass Technology Corporation Address: No.10, Ln. 2, Lianfu St., Luzhu Dist., Taoyuan City 33848, Taiwan (R.O.C.) Tel:+886-3-3226-888 Fax:+886-3-3226-881 Address: No.68-1, Shihbachongsi, Shihding Township, New Taipei City 223, Taiwan, R.O.C. Tel: +886-2-2663-8582
	FCC	TW1079, TW1061, TW1439
	IC	4934E-1, 4934E-2
	VCCI	T-2205 for Telecommunication Test C-4663 for Conducted emission test R-4218 for Radiated emission test G-10812 for radiated disturbance above 1GHz
<input checked="" type="checkbox"/>	Test Site	Cerpass Technology (Suzhou) Co.Ltd. Address: No.66,Tangzhuang Road, Suzhou Industrial Park, Jiangsu 215006, China Tel: +86-512-6917-5888 Fax: +86-512-6917-5666
	CNAS	L5515
	IC	7290A-1, 7290A-2
	VCCI	T-1945 for Telecommunication Test C-2919 for Conducted emission test R-2670 for Radiated emission test G-227 for radiated disturbance above 1GHz
Frequency Range Investigated:		Conducted: from 150kHz to 30 MHz Radiation: from 30 MHz to 6000MHz
Test Distance :		The test distance of radiated emission below 1GHz from antenna to EUT is 10 M. The test distance of radiated emission above 1GHz from antenna to EUT is 3 M.



3.6. Measurement Uncertainty

Where relevant, the following measurement uncertainty levels have been estimated for tests performed on the EUT as specified in CISPR 16-4-2:

Measurement	Frequency	Uncertainty
Conducted emissions(LINE)	9KHz-30MHz	+/- 0.6847dB
Conducted emissions(NEUTRAL)	9KHz-30MHz	+/- 0.6763dB

Measurement	Polarity	Frequency	Uncertainty
Radiated emissions (below 1GHz)	H	30MHz ~ 200MHz	+/- 4.0702dB
		200MHz ~1000MHz	+/- 3.9158dB
	V	30MHz ~ 200MHz	+/- 4.0704dB
		200MHz ~1000MHz	+/- 3.9167dB
Radiated emissions (above 1GHz)	H	1000MHz ~18000MHz	+/- 3.8864dB
		18000MHz ~40000MHz	+/-3.9314dB
	V	1000MHz ~18000MHz	+/- 3.8896dB
		18000MHz ~40000MHz	+/- 3.8766dB

Measurement	Uncertainty
ESD—Rise time tr	6.4%
ESD—Peak current Ip	6%
ESD—Current at 30 ns	6%
ESD—Current at 60 ns	6%
ESD- Charging voltage	1%
RS above 1GHz	±3.81dB
RS under 1GHz	±3.63dB
EFT—Rise time tr	4%
EFT—Peak current Ip	4%
EFT—Current	4%
Surge—Rise time tr	4%



Surge—Peak current I_p	4%
Surge—Current	4%
CS-CND	$\pm 0.66\text{dB}$
CS-Clamp	$\pm 1.04\text{dB}$

This uncertainty represents an expanded uncertainty expressed at approximately the 95% confidence level using a coverage factor of $k=2$.

Consistent with industry standard (e.g. CISPR 32: 2015, clause 11, Measurement Uncertainty) determining compliance with the limits shall be based on the results of the compliance measurement. Consequently the measured emissions being less than the maximum allowed emission result in this being a compliant test or passing test.



4. Test of Conducted Emission

4.1. Test Limit

Conducted Emissions were measured from 150 kHz to 30 MHz with a bandwidth of 9 kHz and return leads of the EUT according to the methods defined in European Standard EN 61000-6-3. The EUT was placed on a nonmetallic stand in a shielded room 0.8 meters above the ground plane. The interface cables and equipment positioning were varied within limits of reasonable applications to determine the position producing maximum conducted emissions.

Table 1 Conducted Emission Limits for AC mains ports

Frequency range (MHz)	Limits (dB μ V)	
	Quasi Peak	Average
0.15 to 0.50	66 to 56	56 to 46
0.50 to 5	56	46
5. to 30.	60	50

Note 1: The lower limits shall apply at the transition frequencies.
 Note 2: The limit decreases linearly with the logarithm of the frequency in the range 0.15 MHz to .50MHz.

Table 2 Conducted Emission Limits for DC power ports

Frequency range (MHz)	Limits (dB μ V)	
	Quasi Peak	Average
0.15 to 0.50	79	66
0.50 to 30	73	60

Note : The limit decreases linearly with the logarithm of the frequency 0.5 MHz.

Table 3 - Limits of conducted common mode (asymmetric mode) disturbance at telecommunication ports in the frequency range 0.15 MHz to 30 MHz

Frequency range (MHz)	Voltage limits dB(μ V)		Current limits dB(μ A)	
	Quasi-peak	Average	Quasi-peak	Average
0.15 to 0.5	84 to 74	74 to 64	40 to 30	30 to 20
0.5 to 30	74	64	30	20

Note 1: The limits decrease linearly with the logarithm of the frequency in the range 0.15 to 0.5 MHz.
 Note 2: The current and voltage disturbance limits are derived for use with an impedance stabilization network (ISN) which presents a common mode (asymmetric mode) impedance of 150 Ω to the telecommunication under test (conversion factor is $20 \log_{10} 150/1 = 44$ dB).

4.2. Test Procedures

- a. The EUT was placed on a desk 0.8 meters height from the metal ground plane and 0.4 meter from the conducting wall of the shielding room and it was kept at least 0.8 meters from any other grounded conducting surface.
- b. Connect EUT to the power mains through a line impedance stabilization network (LISN).
- c. All the support units are connecting to the other LISN.
- d. The LISN provides 50 ohm coupling impedance for the measuring instrument.
- e. The CISPR states that a 50 ohm, 50 micro-Henry LISN should be used.
- f. Both sides of AC line were checked for maximum conducted interference.
- g. The frequency range from 150 kHz to 30 MHz was searched
- h. Set the test-receiver system to Peak Detect Function and Specified Bandwidth with Maximum Hold Mode.

4.3. Typical Test Setup

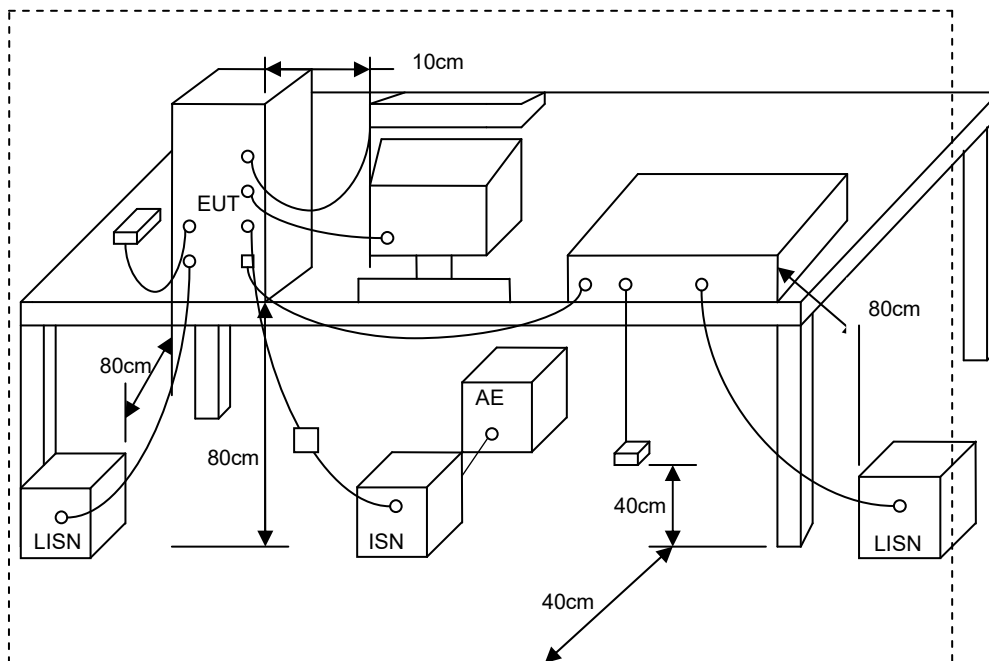



4.4. Measurement equipment

Instrument/Ancillary	Manufacturer	Model No.	Serial No.	Calibration Date	Valid Date.
Test Receiver	R&S	ESCI	100565	2016.03.26	2017.03.25
AMN	R&S	ESH2-Z5	100182	2015.09.06	2016.09.05
Two-Line V-Network	R&S	ENV216	100325	/	/
ISN	FCC	FCC-TLISN-T2-02	20379	2016.03.26	2017.03.25
ISN	FCC	FCC-TLISN-T4-02	20380	2016.03.26	2017.03.25
ISN	FCC	FCC-TLISN-T8-02	20381	2016.03.26	2017.03.25
ISN	TESEQ	ISN ST08	30175	2016.03.26	2017.03.25
Current Probe	R&S	EZ-17	100303	2016.03.26	2017.03.25
Passive Voltage Probe	R&S	ESH2-Z3	100026	2016.03.26	2017.03.25
Pulse Limiter	R&S	ESH3-Z2	100529	2016.03.26	2017.03.25
Temperature/ Humidity Meter	Zhicheng	ZC1-11	CEP-TH-004	2016.03.29	2017.03.28
EZ-EMC	Fala	Ver CT3A1	N/A	N/A	N/A

4.5. Test Result and Data

For this product is supplied by battery, this test item needn't perform.



5. Test of Radiated Emission

5.1. Test Limit

The EUT shall meet the limits of below Table when measured at the measuring distance R in accordance with the methods described in European Standard EN 61000-6-3. If the reading on the measuring receiver shows fluctuations close to the limit, the reading shall be observed for at least 15 s at each measurement frequency; the highest reading shall be recorded, with the exception of any brief isolated high reading, which shall be ignored.

Table – Limits for radiated disturbance at a measuring distance of 10 m

Frequency range MHz	Quasi-peak limits dB(μ V/m)
30 to 230	30
230 to 1000	37
NOTE 1 The lower limit shall apply at the transition frequency. NOTE 2 Additional provisions may be required for cases where interference occurs.	

Table – Limits for radiated disturbance at measuring distance of 3 m

Frequency range GHz	Average limit dB(μ V/m)	Peak limits dB(μ V/m)
1 to 3	50	70
3 to 6	54	74
NOTE The lower limit applies at the transition frequency.		

• Conditional testing procedure:

The highest internal source of an EUT is defined as the highest frequency generated or used within the EUT or on which the EUT operates or tunes.

If the highest frequency of the internal sources of the EUT is less than 108 MHz, the measurement shall only be made up to 1 GHz.

If the highest frequency of the internal sources of the EUT is between 108 MHz and 500 MHz, the measurement shall only be made up to 2 GHz.

If the highest frequency of the internal sources of the EUT is between 500 MHz and 1 GHz, the measurement shall only be made up to 5 GHz.

If the highest frequency of the internal sources of the EUT is above 1 GHz, the measurement shall be made up to 5 times the highest frequency or 6 GHz, whichever is less.



5.2. Test Procedures

- b. The EUT was placed on a relatable table top 0.8 meter above ground.
- c. The EUT was set 10 meters from the interference receiving antenna which was mounted on the top of a variable height antenna tower.
- d. The table was rotated 360 degrees to determine the position of the highest radiation.
- e. The antenna is a half wave dipole and its height is varied between one meter and four meters above ground to find the maximum value of the field strength both horizontal polarization and vertical polarization of the antenna are set to make the measurement.
- f. For each suspected emission the EUT was arranged to its worst case and then tune the antenna tower (from 1 M to 4 M) and turn table (from 0 degree to 360 degrees) to find the maximum reading.
- g. Set the test-receiver system to Peak Detect Function and specified bandwidth with Maximum Hold Mode.
- h. If the emission level of the EUT in peak mode was 3 dB lower than the limit specified, then testing will be stopped and peak values of EUT will be reported, otherwise, the emissions which do not have 3 dB margin will be repeated one by one using the quasi-peak method and reported.

5.3. Typical test Setup

Below 1GHz Test Setup

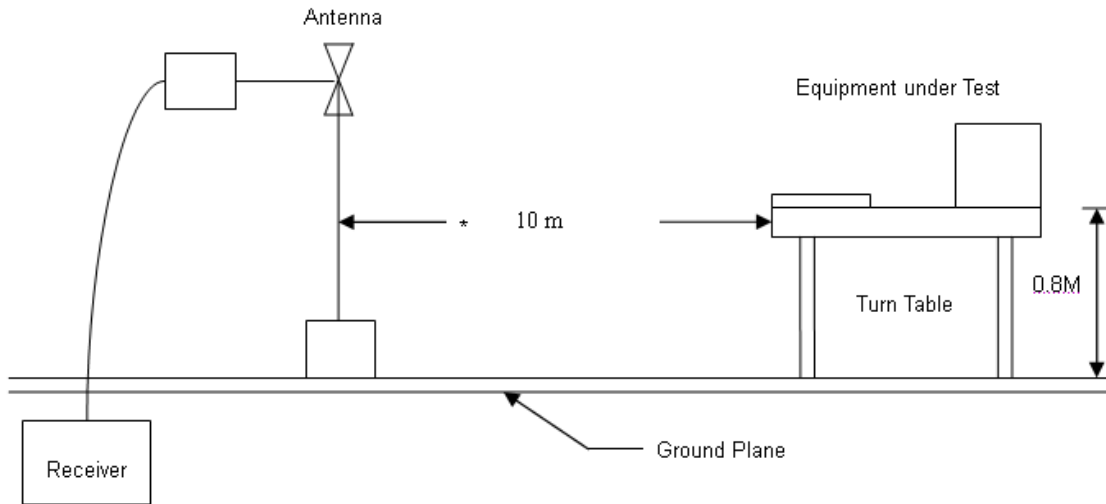

Above 1GHz Test Setup

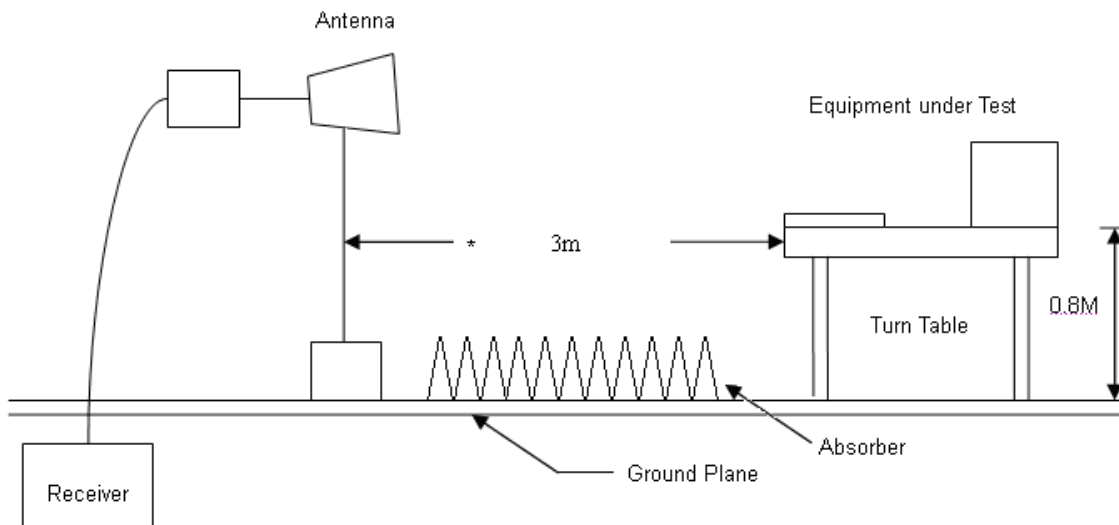



5.4. Measurement equipment

Instrument/Ancillary	Manufacturer	Model No.	Serial No.	Calibration Date	Valid Date.
EMI Test Receiver	R&S	ESCI7	100968	2016.03.26	2017.03.25
Preamplifier	Agilent	87405B	My39500554	2016.03.26	2017.03.25
Preamplifier	Agilent	8449B	3008A02342	2016.03.26	2017.03.25
Bilog Antenna	Sunol Science	JB1	A072414-1	2016.04.16	2017.04.15
Broad-Band Horn Antenna	Schwarzbeck	BBHA9120D	9120D-618	2016.04.16	2017.04.15
Spectrum Analyzer	R&S	FSP40	100324	2016.03.26	2017.03.25
Temperature/ Humidity Meter	Zhicheng	ZC1-11	CEP-TH-001	2016.03.29	2017.03.28
EZ-EMC	Fala	Ver CT3A1	N/A	N/A	N/A



5.5. Test Result and Data (30MHz ~ 1000MHz)

Test Mode :	Mode 1: Normal Operation		
DC Power :	DC 12V	Ant. Polarization:	Horizontal
Temp :	23°C	Humidity :	56%
Pressure(mbar) :	1002	Date:	2016.06.24

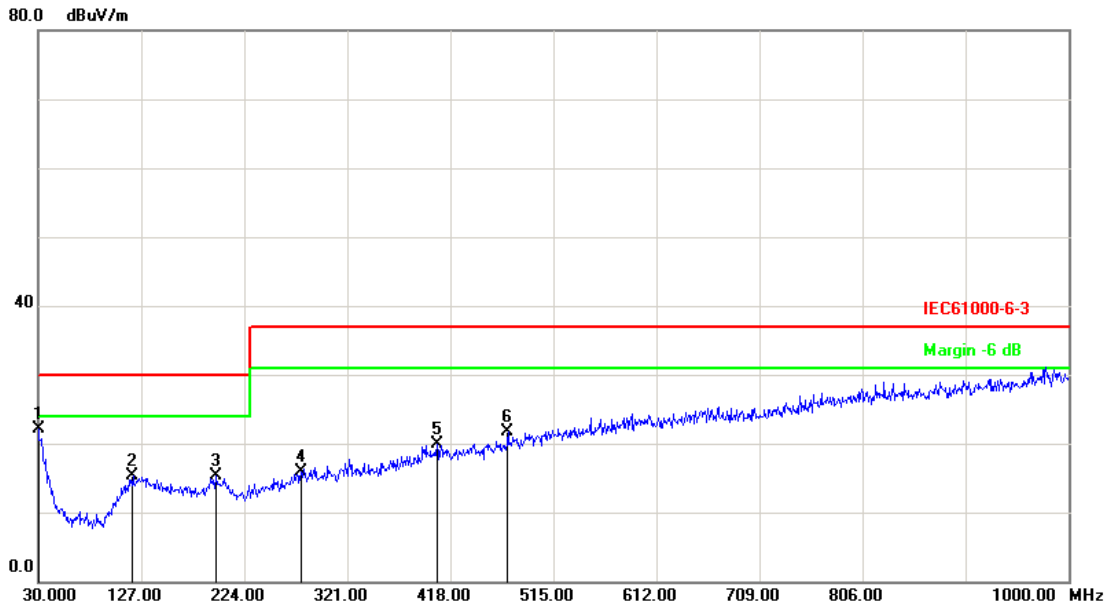

No.	Frequency (MHz)	Factor (dB/m)	Reading (dBuV)	Level (dBuV/m)	Limit (dBuV/m)	Margin (dB)	Det.	Height (cm)	Azimuth (deg)
1	30.0000	-3.26	25.34	22.08	30.00	-7.92	peak	100	131
2	119.2399	-9.71	25.00	15.29	30.00	-14.71	peak	400	0
3	197.8100	-10.09	25.33	15.24	30.00	-14.76	peak	100	182
4	277.3500	-8.99	24.92	15.93	37.00	-21.07	peak	400	186
5	405.3899	-5.26	25.17	19.91	37.00	-17.09	peak	100	352
6	472.3199	-3.92	25.63	21.71	37.00	-15.29	peak	400	167

Note: Measurement Level = Reading Level + Correct Factor



Test Mode :	Mode 1: Normal Operation		
DC Power :	DC 12V	Ant. Polarization:	Vertical
Temp :	23°C	Humidity :	56%
Pressure(mbar) :	1002	Date:	2016.06.24

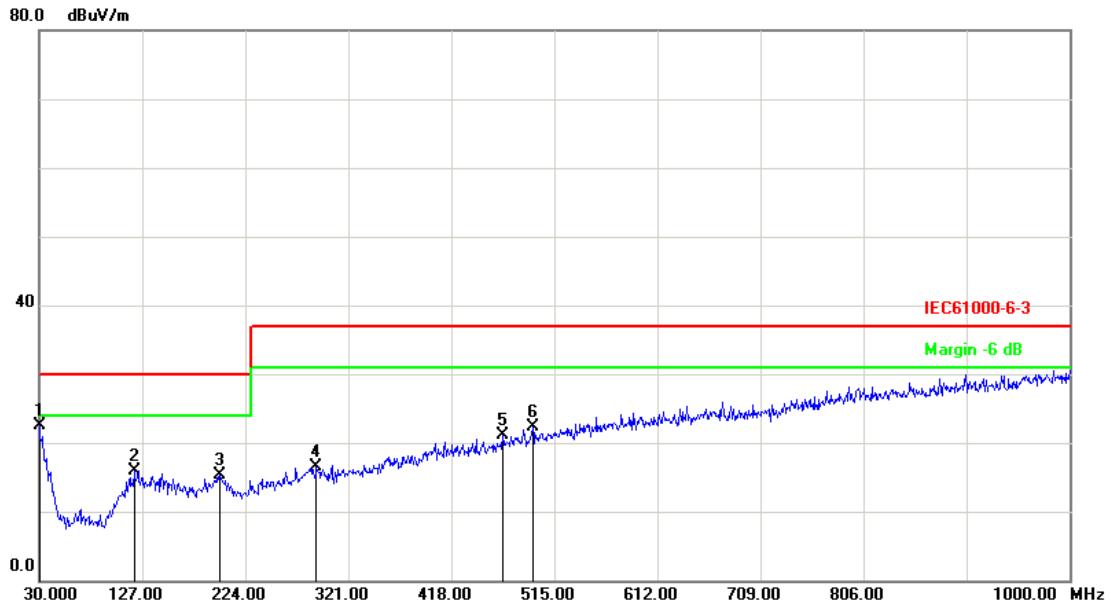

No.	Frequency (MHz)	Factor (dB/m)	Reading (dBuV)	Level (dBuV/m)	Limit (dBuV/m)	Margin (dB)	Det.	Height (cm)	Azimuth (deg)
1	30.0000	-3.26	25.82	22.56	30.00	-7.44	peak	400	97
2	119.2400	-9.71	25.53	15.82	30.00	-14.18	peak	400	170
3	199.7500	-9.94	25.21	15.27	30.00	-14.73	peak	400	170
4	290.9300	-8.79	25.36	16.57	37.00	-20.43	peak	400	21
5	466.5000	-4.11	25.23	21.12	37.00	-15.88	peak	400	360
6	494.6300	-3.19	25.42	22.23	37.00	-14.77	peak	100	257

Note: Measurement Level = Reading Level + Correct Factor



5.6. Test Result and Data (1GHz ~ 6GHz)

Test Mode :	Mode 1: Normal Operation		
DC Power :	DC 12V	Ant. Polarization:	Horizontal
Temp :	23°C	Humidity :	56%
Pressure(mbar) :	1002	Date:	2016.06.24

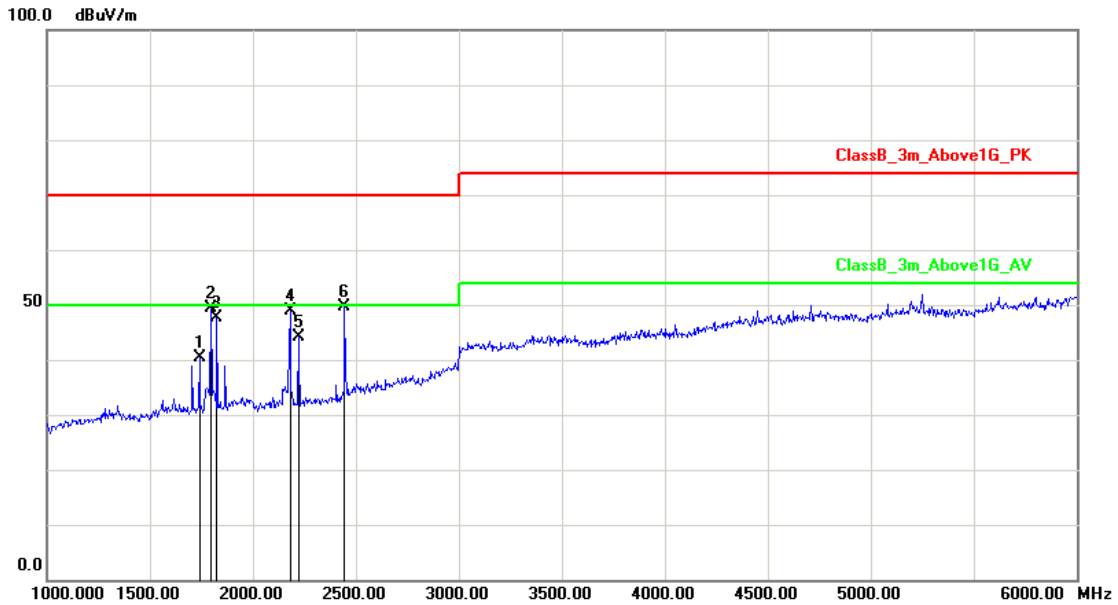

No.	Frequency (MHz)	Factor (dB/m)	Reading (dBuV)	Level (dBuV/m)	Limit (dBuV/m)	Margin (dB)	Det.	Height (cm)	Azimuth (deg)
1	1740.000	-1.95	42.21	40.26	70.00	-29.74	peak	200	241
2	1795.000	-1.79	51.14	49.35	70.00	-20.65	peak	200	226
3	1825.000	-1.70	49.37	47.67	70.00	-22.33	peak	200	211
4	2180.000	-0.28	49.24	48.96	70.00	-21.04	peak	100	94
5	2220.000	-0.08	44.27	44.19	70.00	-25.81	peak	100	109
6	2445.000	1.07	48.50	49.57	70.00	-20.43	peak	200	156

Note: Measurement Level = Reading Level + Correct Factor



Test Mode :	Mode 1: Normal Operation		
DC Power :	DC 12V	Ant. Polarization:	Vertical
Temp :	23°C	Humidity :	56%
Pressure(mbar) :	1002	Date:	2016.06.24

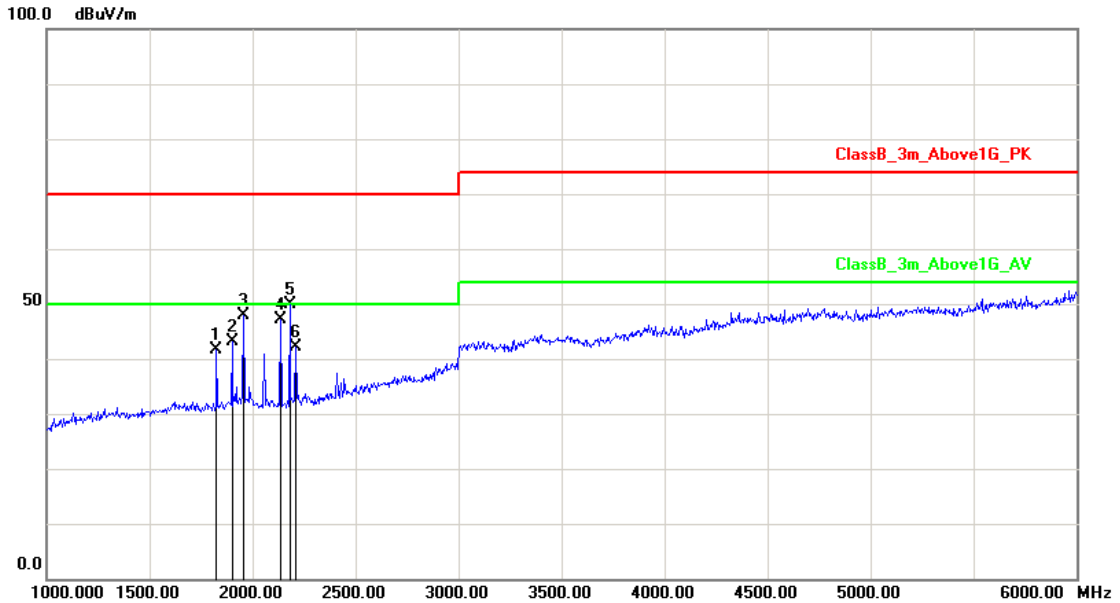

No.	Frequency (MHz)	Factor (dB/m)	Reading (dBuV)	Level (dBuV/m)	Limit (dBuV/m)	Margin (dB)	Det.	Height (cm)	Azimuth (deg)
1	1825.000	-1.70	43.31	41.61	70.00	-28.39	peak	200	9
2	1900.000	-1.49	44.67	43.18	70.00	-26.82	peak	200	69
3	1955.000	-1.33	49.33	48.00	70.00	-22.00	peak	200	129
4	2135.000	-0.51	47.74	47.23	70.00	-22.77	peak	200	221
5	2180.000	-0.28	50.09	49.81	70.00	-20.19	peak	100	236
6	2210.000	-0.13	42.37	42.24	70.00	-27.76	peak	199	251

Note: Measurement Level = Reading Level + Correct Factor

Test engineer: Seben



5.7. Test Photographs (30MHz ~ 1000MHz)

Front View



Rear View

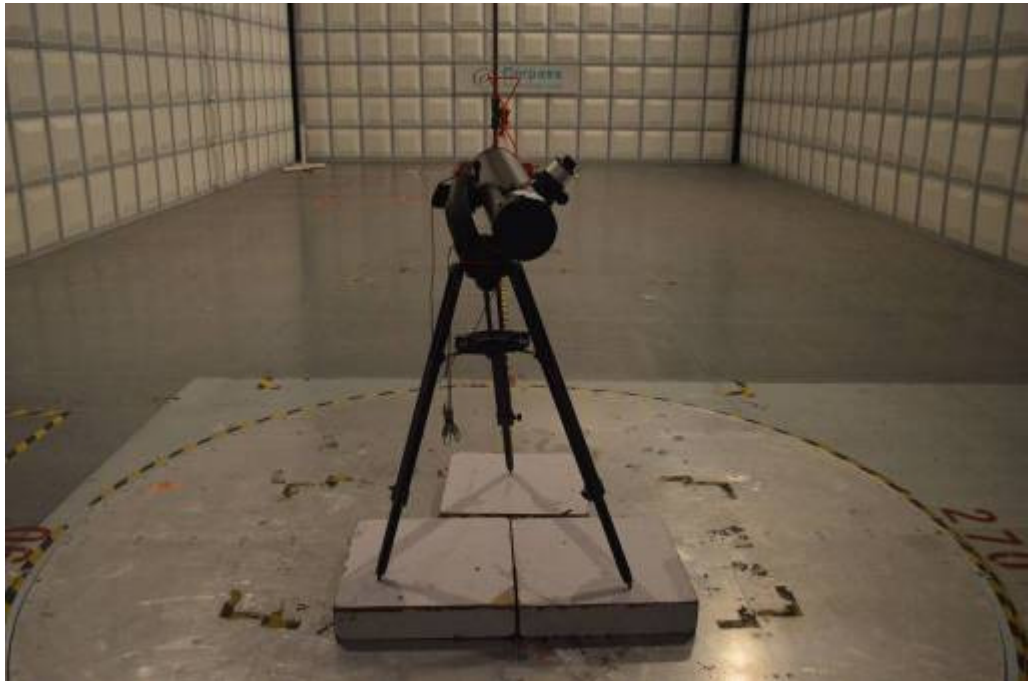



5.8. Test Photographs (1GHz ~ 6GHz)

Front View

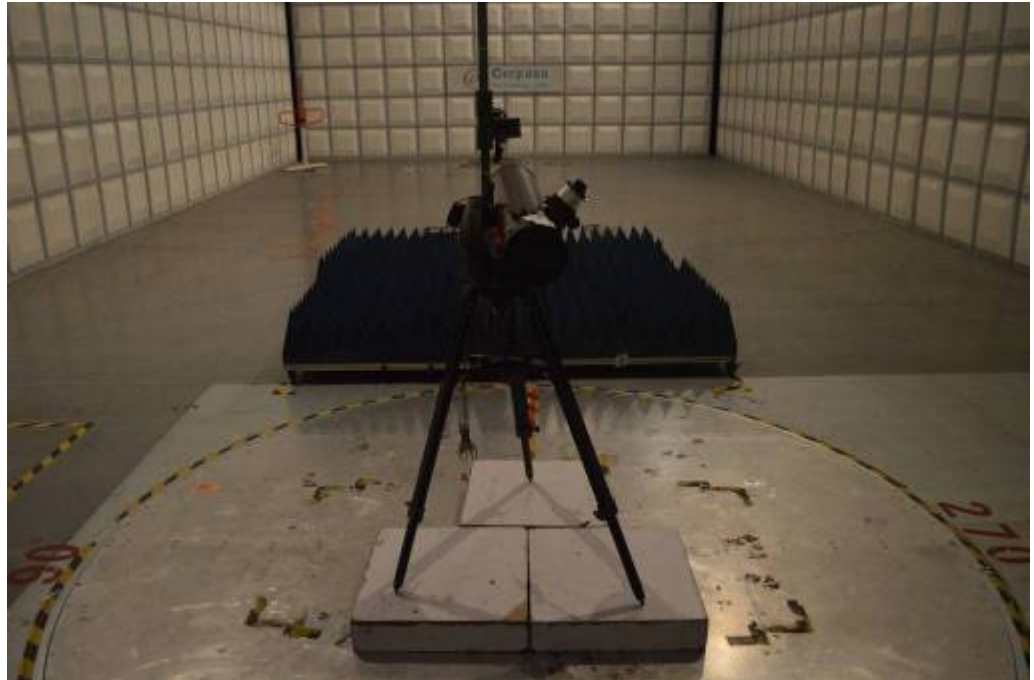

Rear View

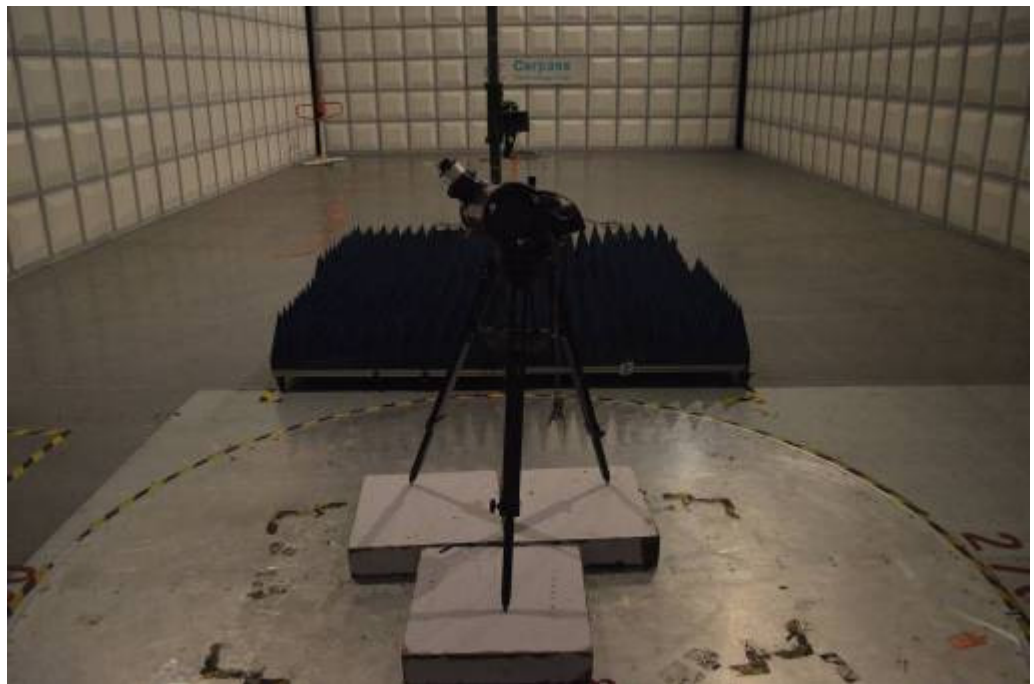



6. Harmonics Test

6.1. Limits Of Harmonics Current Measurement

Limits for Class A equipment

Harmonics Order n	Max. permissible harmonics current A	Harmonics Order n	Max. permissible harmonics current A
Odd harmonics		Even harmonics	
3	2.30	2	1.08
5	1.14	4	0.43
7	0.77	6	0.30
9	0.40	8<=n<=40	0.23x8/n
11	0.33		
13	0.21		
15<=n<=39	0.15x15/n		

(b) Limits for Class B equipment

For Class B equipment, the harmonics of the input current shall not exceed the values given in Table that is the limit of Class A multiplied by a factor of 1,5.

(c) Limits for Class C equipment

Harmonics Order n	Maximum permissible harmonic current expressed as a percentage of the input current at the fundamental frequency %
2	2
3	$30 \cdot \lambda^*$
5	10
7	7
9	5
11<n<39 (odd harmonics only)	3

* λ is the circuit power factor

(d) Limits for Class D equipment

Harmonics Order n	Maximum permissible harmonic current per watt mA/W	Maximum permissible harmonic current A
3	3.4	2.30
5	1.9	1.14
7	1.0	0.77
9	0.5	0.40
11	0.35	0.33
11 < n < 39 (odd harmonics only)	3.85/n	See limit of Class A

NOTE: According to section 7 of EN 61000-3-2, the above limits for all equipment except for lighting equipment having an active input power > 75 W and no limits apply for equipment with an



active input power up to and including 75 W.

6.2. Measurement equipment

Instrument/Ancillary	Manufacturer	Model No.	Serial No.	Calibration Date	Valid Date.
EMC Emission Tester	EMCPARTNER	Harmonics-1000	159	2016.03.26	2017.03.25
Temperature/ Humidity Meter	Zhicheng	ZC1-11	CEP-TH-004	2016.03.29	2017.03.28
HARCS	EMC Partner AG	Ver 4.18	N/A	N/A	N/A

6.3. Test Result and Data

For this product is supplied by battery, this test item needn't perform.



7. Voltage Fluctuations Test

7.1. Test Procedure

The equipment shall be tested under the conditions of **Clause 5**.

The total impedance of the test circuit, excluding the appliance under test, but including the internal impedance of the supply source, shall be equal to the reference impedance. The stability and tolerance of the reference impedance shall be adequate to ensure that the overall accuracy of $\pm 8\%$ is achieved during the whole assessment procedure.

7.2. Measurement equipment

Instrument/Ancillary	Manufacturer	Model No.	Serial No.	Calibration Date	Valid Date.
EMC Emission Tester	EMCPARTNER	Harmonics-1000	159	2016.03.26	2017.03.25
Temperature/ Humidity Meter	Zhicheng	ZC1-11	CEP-TH-004	2016.03.29	2017.03.28
HARCS	EMC Partner AG	Ver 4.18	N/A	N/A	N/A

7.3. Test Result and Data

For this product is supplied by battery, this test item needn't perform.



8. Electrostatic Discharge Immunity Test

8.1. Test Procedure

- a. In the case of air discharge testing the climatic conditions shall be within the following ranges:
 - ambient temperature: 15°C to 35°C;
 - relative humidity : 30% to 60%;
 - atmospheric pressure : 86 KPa (860 hPa) to 106 KPa (1060 hPa).
- b. Test programs and software shall be chosen so as to exercise all normal modes of operation of the EUT. The use of special exercising software is encouraged, but permitted only where it can be shown that the EUT is being comprehensively exercised.
- c. The test voltage shall be increased from the minimum to the selected test severity level, in order to determine any threshold of failure. The final severity level should not exceed the product specification value in order to avoid damage to the equipment.
- d. The test shall be performed with both air discharge and contact discharge. On reselected points at least 10 single discharges (in the most sensitive polarity) shall be applied on air discharge. On reselected points at least 25 single discharges (in the most sensitive polarity) shall be applied on contact discharge.
- e. For the time interval between successive single discharges an initial value of one second is recommended. Longer intervals may be necessary to determine whether a system failure has occurred.
- f. In the case of contact discharges, the tip of the discharge electrode shall touch the EUT before the discharge switch is operated.
- g. In the case of painted surface covering a conducting substrate, the following procedure shall be adopted :
 - ✧ If the coating is not declared to be an insulating coating by the equipment manufacturer, then the pointed tip of the generator shall penetrate the coating so as to make contact with the conducting substrate.
 - ✧ Coating declared as insulating by the manufacturer shall only be submitted to the air discharge.
 - ✧ The contact discharge test shall not be applied to such surfaces.
- h. In the case of air discharges, the round discharge tip of the discharge electrode shall be approached as fast as possible (without causing mechanical damage) to touch the EUT . After each discharge, the ESD generator (discharge electrode) shall be removed from the EUT. The generator is then retriggered for a new single discharge. This procedure shall be repeated until the discharges are completed. In the case of an air discharge test, the discharge switch, which is used for contact discharge, shall be closed.

8.2. Test Setup for Tests Performed in Laboratory

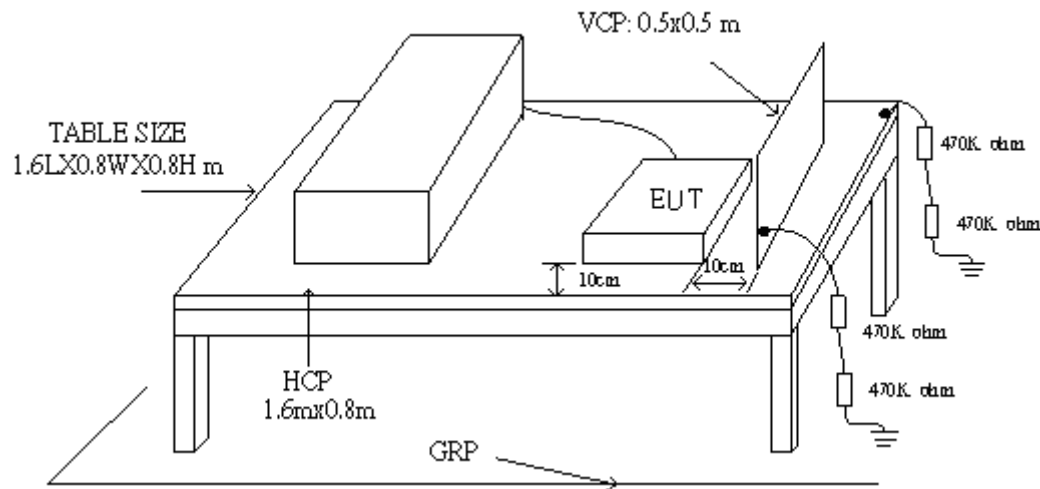

The test setup consists of the test generator, EUT and auxiliary instrumentation necessary to perform DIRECT and INDIRECT application of discharges to the EUT as applicable, in the follow manner :

- Contact Discharge to the conductive surfaces and to coupling plane;
- Air Discharge at insulating surfaces.

The preferred test method is that of type tests performed in laboratories and the only accepted method of demonstrating conformance with this standard. The EUT was arranged as closely as possible to arrangement in final installed conditions.

A ground reference plane was provided on the floor of the test site. It was a metallic sheet (copper or aluminum) of 0.25 mm, minimum thickness; other metallic may be used but they shall have at least 0.65 mm thickness. In the Exclusive Certification Corp., we provided 1 mm thickness stainless steel ground reference plane. The minimum size of the ground reference plane is 2.5 m x 2.5 m, the exact size depending on the dimensions of the EUT. It was connected to the protective grounding system.

The EUT was arranged and connected according to its functional requirements. A distance of 1m minimum was provided between the EUT and the wall of the lab. and any other metallic structure. In cases where this length exceeds the length necessary to apply the discharges to the selected points, the excess length shall, where possible, be placed non-inductively off the ground reference plane and shall not come closer than 0.2m to other conductive parts in the test setup.

Where the EUT is installed on a metal table, the table was connected to the reference plane via a cable with a 470k ohm resistor located at each end, to prevent a build-up of charge. The test setup was consist a wooden table, 0.8m high, standing on the ground reference plane. A HCP, 1.6 m x 0.8 m, was placed on the table. The EUT and cables was isolated from the HCP by an insulating support 0.5 mm thick. The VCP size, 0.5 m x 0.5 m.



8.3. Test Severity Levels

Contact Discharge		Air Discharge	
Level	Test Voltage (kV) of Contact discharge	Level	Test Voltage (kV) of Air Discharge
1	±2	1	±2
2	±4	2	±4
3	±6	3	±8
4	±8	4	±15
X	Specified	X	Specified

Remark: "X" is an open level.

8.4. Measurement equipment

Instrument/Ancillary	Manufacturer	Model No.	Serial No.	Calibration Date	Valid Date.
ESD Simulator	EM Test	dito	V0714102399	2016.04.21	2017.04.20
Tonometer	shanghaifengyun	DYM3	3251	2015.12.21	2016.12.20
Dehumidifier	ZEDO	ZD-220LB	CEP-TH-01	N/A	N/A
Humidifier	YADU	YZ-DS251C	CEP-TH-02	N/A	N/A
Temperature/ Humidity Meter	feiyan	N/A	102	2016.03.29	2017.03.28



8.5. Test Result and Data

Final Test Result : **PASS**
 Required performance criteria : B
 Basic Standard : IEC 61000-4-2
 Product Standard : EN 61000-6-1
 Test Voltage : ±2 / ±4 / ±8 KV for air discharge,
 ±2 / ±4 KV for contact discharge
 Temperature : 24 °C
 Relative Humidity : 50 %
 Atmospheric Pressure : 100kPa
 Test Date : Jun 23, 2016

Test Mode 1

	Contact Discharge								Air Discharge							
	25 times / each								10 times / each							
Voltage	2 kV		4 kV		6 kV		8 kV		2 kV		4 kV		8 kV		10 kV	
Point\Polarity	+	-	+	-	+	-	+	-	+	-	+	-	+	-	+	-
HCP	A	A	A	A	---	---	---	---	---	---	---	---	---	---	---	---
VCP	A	A	A	A	---	---	---	---	---	---	---	---	---	---	---	---
1-9	---	---	---	---	---	---	---	---	A	A	A	A	A	A	---	---
10-43	A	A	A	A	---	---	---	---	---	---	---	---	---	---	---	---
44-49	---	---	---	---	---	---	---	---	A	A	A	A	A	A	---	---

Test engineer: *Cebew*



8.6. Test Photographs

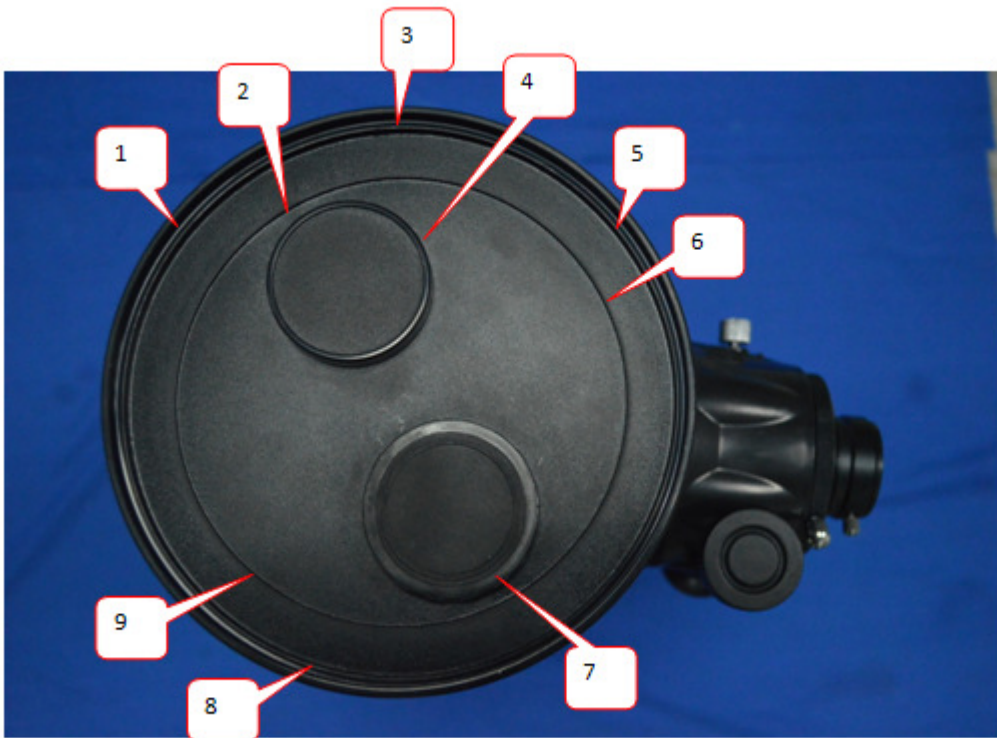

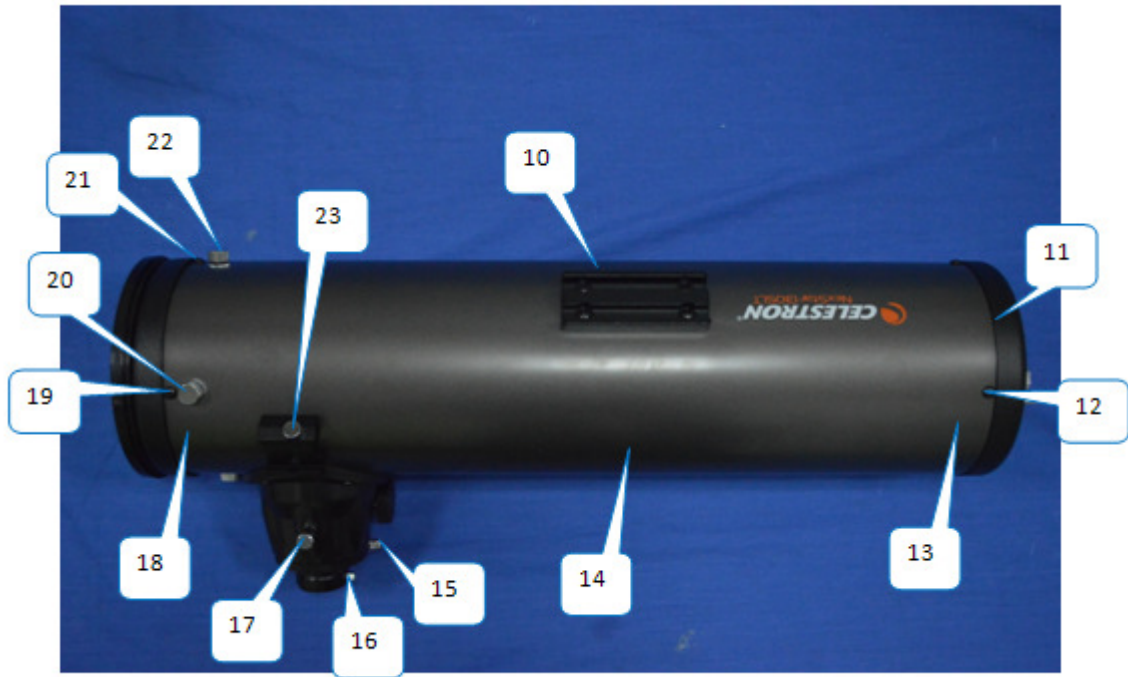

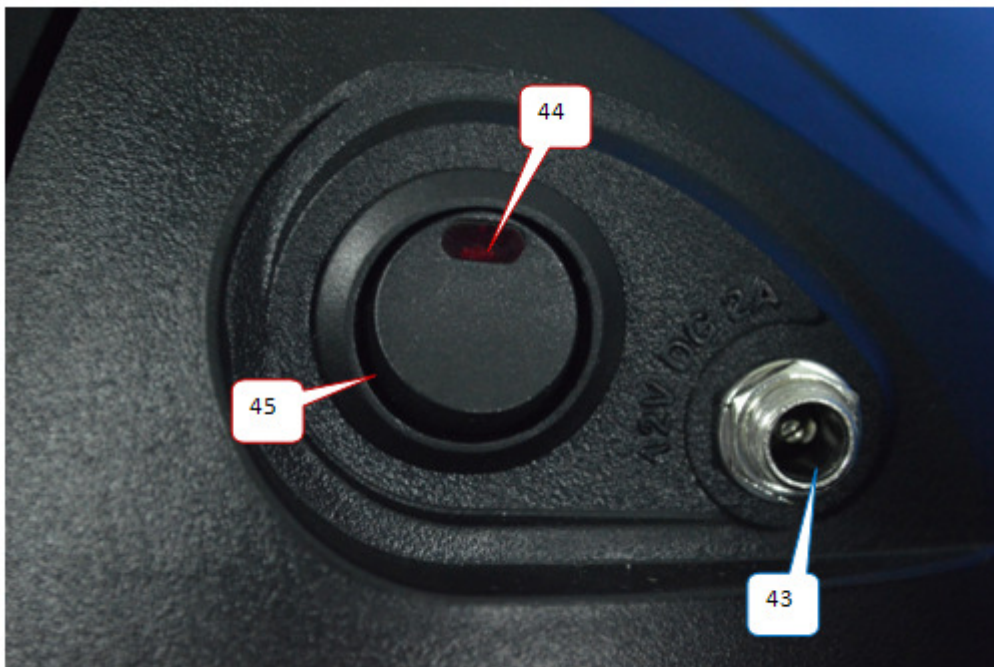
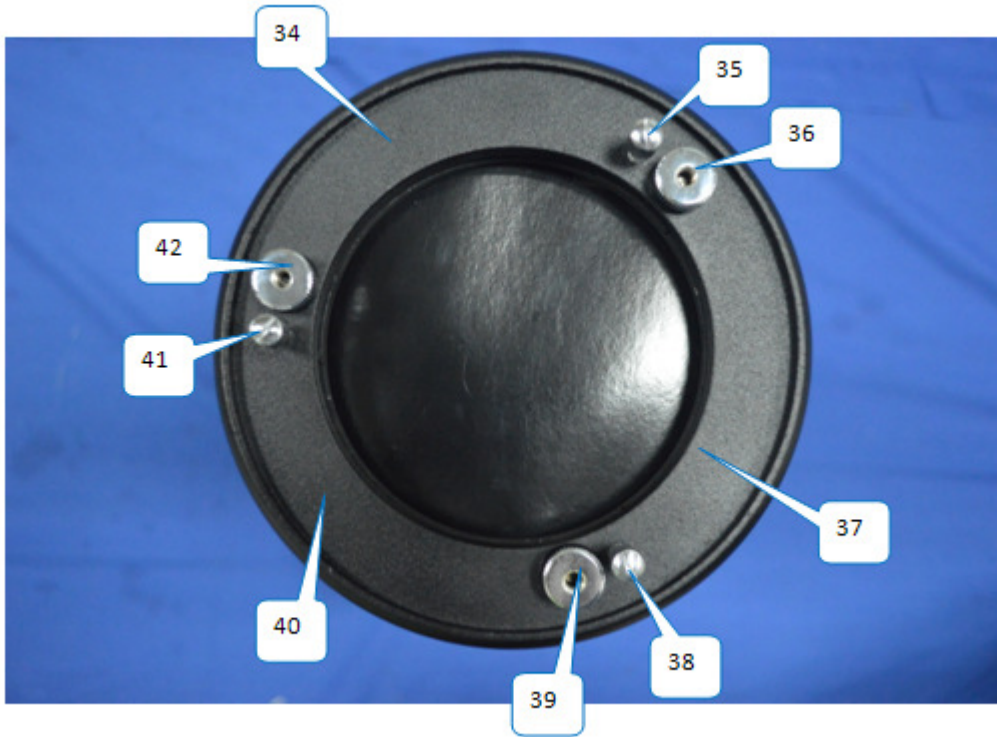

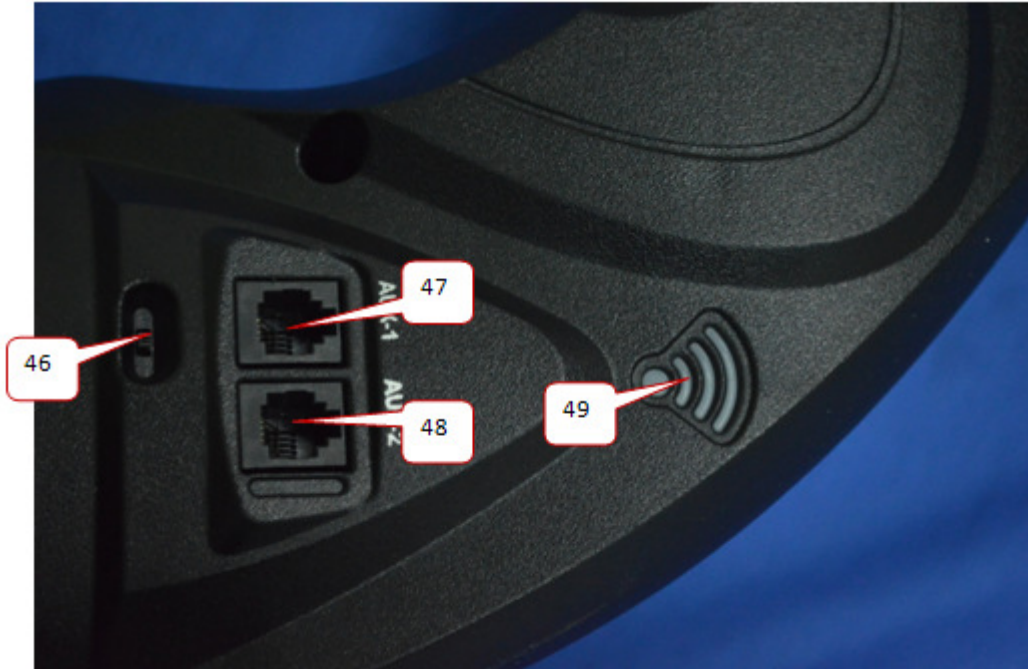



9. Radio Frequency electromagnetic field immunity test

9.1. Test Procedure

- a. The equipment to be tested is placed in the center of the enclosure on a wooden table. The equipment is then connected to power and signal leads according to pertinent installation instructions.
- b. The required field strength is determined by placing the field strength meter(s) on top of or directly alongside the equipment under test and monitoring the field strength meter via a remote field strength indicator outside the enclosure while adjusting the continuous-wave to the applicable antennae.
- c. The test is normally performed with the antenna facing the most sensitive side of the EUT. The polarization of the field generated by the bucolical antenna necessitates testing each position twice, once with the antenna positioned vertically and again with the antenna positioned horizontally. The circular polarization of the field from the log-spiral antenna makes a change of position of the antenna unnecessary.
- d. At each of the above conditions, the frequency range is swept 80-1000 MHz, 1400-2000MHz, 2000-2700MHz, pausing to adjust the R.F. signal level or to switch oscillators and antenna. The rate of sweep is in the order of $1.5 \cdot 10^{-3}$ decades/s. The sensitive frequencies or frequencies of dominant interest may be discretely analyzed.

9.2. Test Severity Levels

Frequency Band	
Level	Test field strength (V/m)
1	1
2	3
3	10
X	Specified

Remark: "X" is an open class.



9.3. Measurement equipment

Instrument/Ancillary	Manufacturer	Model No.	Serial No.	Calibration Date	Valid Date.
Signal Generator	R&S	SML03	103287	2016.03.26	2017.03.25
Power Sensor	R&S	NR P-Z91	100383	2016.03.26	2017.03.25
Power Sensor	R&S	NRP-Z91	100384	2016.03.26	2017.03.25
Power Meter	R&S	NRP	101206	2016.03.26	2017.03.25
Power Amplifier	BONN	BLWA0830-16 0/100/40D	076659	2016.03.26	2017.03.25
Istropic Electric Field Probe	EST.LINDGRE N	HI-6105	137445	2015.11.20	2016.11.19
EMS Antenna	R&S	HL046E	100028	N/A	N/A
Temperature/ Humidity Meter	feiyang	N/A	101	2016.03.29	2017.03.28
EMC-32	Rohde&Schwa rz	Ver 6.10.0	N/A	N/A	N/A



9.4. Test Result and Data

Final Test Result : **PASS**
 Required performance criteria : A
 Basic Standard : IEC 61000-4-3
 Product Standard : EN 61000-6-1
 Frequency Range : 80-1000 MHz, 1400-2000MHz, 2000-2700MHz
 Temperature : 21 °C
 Relative Humidity : 51%
 Atmospheric Pressure : 101 kPa
 Test Date : Jun 23, 2016

Test Mode 1

Modulation : AM 80% , 1KHz sine wave , Dwell time: 3.0 S				
Frequency Step Size : 1 % of preceding frequency value				
Frequency (MHz)	Antenna Polarization	face	Field strength (V/m)	Result
80~1000	Vertical	Front	3 V/m	
80~1000	Vertical	Rear	3 V/m	
80~1000	Vertical	Left	3 V/m	
80~1000	Vertical	Right	3 V/m	
80~1000	Horizontal	Front	3 V/m	
80~1000	Horizontal	Rear	3 V/m	
80~1000	Horizontal	Left	3 V/m	
80~1000	Horizontal	Right	3 V/m	
1400~2000	Vertical	Front	3 V/m	
1400~2000	Vertical	Rear	3 V/m	
1400~2000	Vertical	Left	3 V/m	
1400~2000	Vertical	Right	3 V/m	
1400~2000	Horizontal	Front	3 V/m	
1400~2000	Horizontal	Rear	3 V/m	
1400~2000	Horizontal	Left	3 V/m	
1400~2000	Horizontal	Right	3 V/m	
2000~2700	Vertical	Front	1 V/m	
2000~2700	Vertical	Rear	1 V/m	
2000~2700	Vertical	Left	1 V/m	
2000~2700	Vertical	Right	1 V/m	
2000~2700	Horizontal	Front	1 V/m	
2000~2700	Horizontal	Rear	1 V/m	
2000~2700	Horizontal	Left	1 V/m	
2000~2700	Horizontal	Right	1 V/m	

Test engineer:



9.5. Test Photographs





10. Electrical Fast Transient/ Burst Immunity Test

10.1. Test Procedure

- a. In order to minimize the effect of environmental parameters on test results, the climatic conditions when test is carrying out shall comply with the following requirements:
 - ✧ ambient temperature: 15°C to 35°C;
 - ✧ relative humidity : 45% to 75%;
 - ✧ Atmospheric pressure: 86 Kpa (860 hPa) to 106 Kpa (1060 hPa).
- b. In order to minimize the effect of environmental parameters on test results, the electromagnetic environment of the laboratory shall not influence the test results.
- c. The variety and diversity of equipment and systems to be tested make it difficult to establish general criteria for the evaluation of the effects of fast transients/bursts on equipment and systems.
- d. Test on Power Line:
 - ✧ The EFT/B-generator was located on the GRP.. The length from the EFT/B-generator to the EUT is not exceeding 1 m.
 - ✧ The EFT/B-generator provides the ability to apply the test voltage in a non-symmetrical condition to the power supply input terminals of the EUT.
- e. Test on Communication Lines
 - ✧ The coupling clamp is composed of a clamp unit for housing the cable (length more than 3 m), and was placed on the GRP.
 - ✧ The coupling clamp provides the ability of coupling the fast transient/bursts to the cable under test.
- f. The test results may be classified on the basic of the operating conditions and the functional specification of the equipment under test, according to the following performance criteria :
 - ✧ Normal performance within the specification limits.
 - ✧ Temporary degradation or loss of function or performance which is self-recoverable.
 - ✧ Temporary degradation or loss of function or performance which requires operator intervention or system reset.
 - ✧ Degradation or loss of function which is not recoverable due to damage of equipment (components).



10.2. Test Severity Levels

The following test severity levels are recommended for the fast transient/burst test :

Open circuit output test voltage $\pm 10\%$		
Level	On Power Supply	On I/O signal, data and control line
1	0.5 kV	0.25 kV
2	1.0 kV	0.50 kV
3	2.0 kV	1.00 kV
4	4.0 kV	2.00 kV
X	Specified	Specified

Remark : " X " is an open level. The level is subject to negotiation between the user and the manufacturer or is specified by the manufacturer.

10.3. Measurement equipment

Instrument/Ancillary	Manufacturer	Model No.	Serial No.	Calibration Date	Valid Date.
TRANSIENT	EMCPARTNER	TRA2000IN6	901	2016.03.26	2017.03.25
CDN	EMCPARTNER	CDN2000-06-3 2	121	2016.03.26	2017.03.25
Coupling clamp	EMCPARTNER	CN-EFT1000	547	2016.03.26	2017.03.25
Temperature/ Humidity Meter	Zhicheng	ZC1-11	CEP-TH-005	2016.03.29	2017.03.28

10.4. Test Result and Data

For this product is supplied by battery, this test item needn't perform.



11. Surge Immunity Test

11.1. Test Procedure

a. Climatic conditions

The climatic conditions shall comply with the following requirements :

- ✧ ambient temperature : 15 °C to 35 °C
- ✧ relative humidity : 10 % to 75 %
- ✧ atmospheric pressure : 86 kPa to 106 kPa (860 hPa to 1060 hPa)

b. Electromagnetic conditions

the electromagnetic environment of the laboratory shall not influence the test results.

c. The test shall be performed according the test plan that shall specify the test set-up with

- ✧ generator and other equipment utilized;
- ✧ test level (voltage/current);
- ✧ generator source impedance;
- ✧ internal or external generator trigger;
- ✧ number of tests : at least five positive and five negative at the selected points;
- ✧ repetition rate : maximum 1/min.
- ✧ inputs and outputs to be tested;
- ✧ representative operating conditions of the EUT;
- ✧ sequence of application of the surge to the circuit;
- ✧ phase angle in the case of AC. power supply;
- ✧ actual installation conditions, for example :

AC : neutral earthed,

DC : (+) or (-) earthed to simulated the actual earthing conditions.

- d. If not otherwise specified the surges have to be applied synchronized to the voltage phase at the zero-crossing and the peak value of the AC. voltage wave (positive and negative).
- e. The surges have to be applied line to line and line(s) and earth. When testing line to earth, the test voltage has to be applied successively between each of the lines and earth, if there is no other specification.
- f. The test procedure shall also consider the non-linear current-voltage characteristics of the equipment under test. Therefore the test voltage has to be increased by steps up to the test level specified in the product standard or test plan.
- g. All lower levels including the selected test level shall be satisfied. For testing the secondary protection, the output voltage of the generator shall be increased up to the worst-case voltage breakdown level (let-through level) of the primary protection.
- h. If the actual operating signal sources are not available, that may be simulated. Under no circumstances may the test level exceed the product specification. The test shall be carried out according to a test plan.
- i. To find all critical points of the duty cycle of the equipment, a sufficient number of positive and negative test pulses shall be applied. For acceptance test previously unstressed equipment shall be used to the protection devices shall be replaced.



11.2. Test Severity Level

Level	Open-circuit test voltage, $\pm 10\%$, kV
1	0.5
2	1.0
3	2.0
4	4.0
X	Specified

NOTE: "X" is an open class. This level can be specified in the product specification.

11.3. Measurement equipment

Instrument/Ancillary	Manufacturer	Model No.	Serial No.	Calibration Date	Valid Date.
TRANSIENT	TESEQ	NSG 3060	1830	2016.02.04	2017.02.03
CDN	TESEQ	CDN 3061	1575	2016.02.04	2017.02.03
CDN	TESEQ	CNV508T5	P 1546167499	2016.02.17	2017.02.16
CDN	TESEQ	CDN HSS-2	41020	2016.02.24	2017.02.23
TRANSIENT	EMCPARTNER	TRA2000IN6	901	2016.03.26	2017.03.25
CDN	EMCPARTNER	CDN-UTP8	021	2016.03.26	2017.03.25
CDN	EMCPARTNER	CDN2000-06-32	121	2016.03.26	2017.03.25
Temperature/ Humidity Meter	Zhicheng	ZC1-11	CEP-TH-005	2016.03.29	2017.03.28

11.4. Test Result and Data

For this product is supplied by battery, this test item needn't perform.



12. Conduction Disturbances induced by Radio-Frequency Fields

12.1. Test Procedure

- a. The EUT shall be operated within its intended climatic conditions. The temperature and relative humidity should be recorded.
- b. This test method test can be performed without using a sell shielded enclosure. This is because the disturbance levels applied and the geometry of the setups are not likely to radiated a high amount of energy, especially at the lower frequencies. If under certain circumstances the radiated energy is too high, a shielded enclosure has to be used.
- c. The test shall be performed with the test generator connected to each of the coupling and decoupling devices in turn while the other non-excited RF-input ports of the coupling devices are terminated by a 50 ohm load resistor.
- d. The frequency range is swept from 150 KHz to 80 MHz, using the signal levels established during the setting process, and with the disturbance signal 80% amplitude modulated with a 1KHz sign wave, pausing to adjust the RF-signal level or to switch coupling devices as necessary. The rate of sweep shall no exceed 1.5 x 10⁻³ decades/s. Where the frequency is swept incrementally, the step size shall no exceed 1% of the start and thereafter 1% of the preceding frequency value.
- e. The dwell time at each frequency shall not be less than the time necessary for the EUT to be exercised, and able to respond. Sensitive frequencies e.g. clock frequency (ies) and harmonics or frequencies of dominant interest shall be analyzed separately.
- f. An alternative test procedure may be adopted, wherein the frequency range is swept incrementally, with a step size not exceeding 4% of the start ad thereafter 4% of the preceding frequency value. The test level should be at least twice the value of the specified test level.
- g. In cases of dispute, the test procedure using a step size not exceeding 1% of the start and thereafter 1% of preceding frequency value shall take precedence.
- h. Attempts should be made to fully exercise the EUT during testing, and to fully interrogate all exercise modes selected for susceptibility.
- i. The use of special exercising programs is recommended.
- j. Testing shall be performed according to a Test Plan, which shall be included in the test report.
- k. It may be necessary to carry out some investigatory testing in order to establish some aspects of the test plan.



12.2. Test Severity Levels

Level	Voltage Level (EMF),
1	1 V
2	3 V
3	10 V
x	Specified

NOTE - x is an open class. This level can be specified in the product specification.

12.3. Measurement equipment

Instrument/Ancillary	Manufacturer	Model No.	Serial No.	Calibration Date	Valid Date.
Conducted immunity test system	FRANKONIA	CIT-10/75	102D1294	2016.03.26	2017.03.25
EM Injection clamp	FCC	F-203I-23MM	536	2016.03.26	2017.03.25
CDN	FRANKONIA	CDN-T2	A3010029	2016.03.26	2017.03.25
CDN	FRANKONIA	CDN-T4	A3015017	2016.03.26	2017.03.25
CDN	FRANKONIA	CDN-T8	A3022010	2016.03.26	2017.03.25
CDN	FRANKONIA	CDN-M2	A3002037	2016.03.26	2017.03.25
CDN	FRANKONIA	CDN-M2+M3	A3011102	2016.03.26	2017.03.25
CDN	FCC	CDN-M5/32	A3013024	2016.03.26	2017.03.25
6 dB Attenuator	FRANKONIA	N/A	N/A	2016.03.26	2017.03.25
Temperature/ Humidity Meter	Zhicheng	ZC1-11	CEP-TH-005	2016.03.29	2017.03.28
EN61000-4-6	Hubert GmbH	Ver 2.21	N/A	N/A	N/A

12.4. Test Result and Data

For this product is supplied by battery, this test item needn't perform.

13. Power Frequency Magnetic Field Immunity Tests

13.1. Test Setup

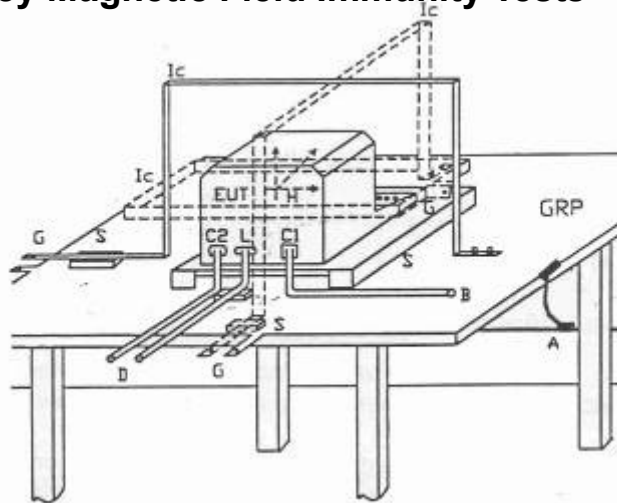

GPR	: Ground plane	C1	: Power supply circuit
A	: Safety earth	C2	: Signal circuit
S	: Insulating support	L	: Communication line
EUT	: Equipment under test	B	: To power supply source
Lc	: Induction coil	D	: To signal source, simulator
E	: Earth terminal	G	: To the test generator

13.2. Test Severity Levels

Level	Magnetic field strength A/m
1	1
2	3
3	10
4	30
5	100
X ¹⁾	special

NOTE 1 "X" is an open level. This level can be given in the product specification.

13.3. Measurement equipment

Instrument/Ancillary	Manufacturer	Model No.	Serial No.	Calibration Date	Valid Date.
TRANSIENT	EMCPARTNER	TRA2000IN6	901	2016.03.26	2017.03.25
H-Filed-Loop	EMCPARTNER	MF1000-1	144	2016.03.26	2017.03.25
Temperature/ Humidity Meter	Zhicheng	ZC1-11	CEP-TH-005	2016.03.29	2017.03.28



13.4. Test Result and Data

Final Test Result : **PASS**
Required performance criteria : A
Basic Standard : IEC 61000-4-8
Product Standard : EN 61000-6-1
Temperature : 24 °C
Relative Humidity : 51 %
Atmospheric Pressure : 102 kPa
Test Date : Jun 23, 2016

Test Mode 1

Power Frequency Magnetic Field : <u>50</u> Hz, <u>60</u> Hz, <u>3</u> A/m		
Coil Orientation	Testing duration	Results
X-axis	1.0 Min	A
Y-axis	1.0 Min	A
Z-axis	1.0 Min	A

Test engineer: *Ceben*



13.5. Test Photographs

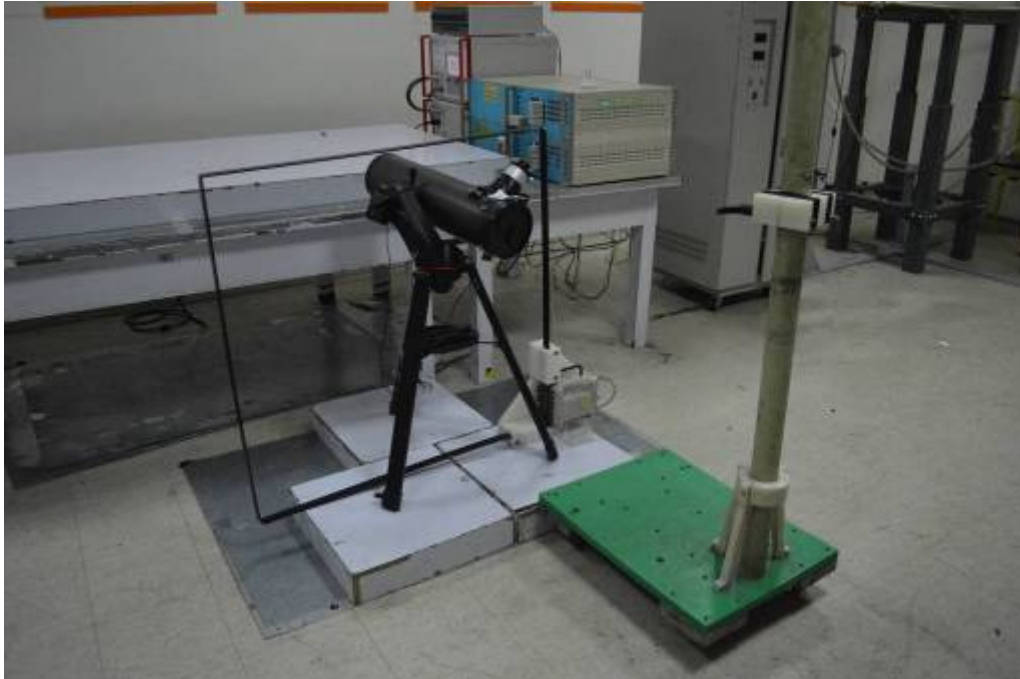



14. Voltage Dips and Voltage Interruptions Immunity Test Setup

14.1. Test Conditions

1. Test of interval : 10 sec.
2. Level and duration : Sequence of 3 dips/interrupts.
3. Voltage rise (and fall) time : 1 ~ 5 μ s.
4. Test severity :

Voltage dips and Interrupt reduction (%)	Source voltage and frequency	Test Duration (Cycle)
0%	230V / 50Hz	250
	230V / 60Hz	300
0%	230V / 50Hz	0.5
70%	230V / 50Hz	25
	230V / 60Hz	30
0%	230V / 50Hz	1

14.2. Measurement equipment

Instrument/Ancillary	Manufacturer	Model No.	Serial No.	Calibration Date	Valid Date.
TRANSIENT	EMCPARTNER	TRA2000IN6	901	2016.03.26	2017.03.25
Temperature/ Humidity Meter	Zhicheng	ZC1-11	CEP-TH-005	2016.03.29	2017.03.28

14.3. Test Result and Data

For this product is supplied by battery, this test item needn't perform.



15. Photographs of EUT

1) EUT Photo



2) EUT Photo





3) EUT Photo



4) EUT Photo





5) EUT Photo



6) EUT Photo





7) EUT Photo



8) EUT Photo

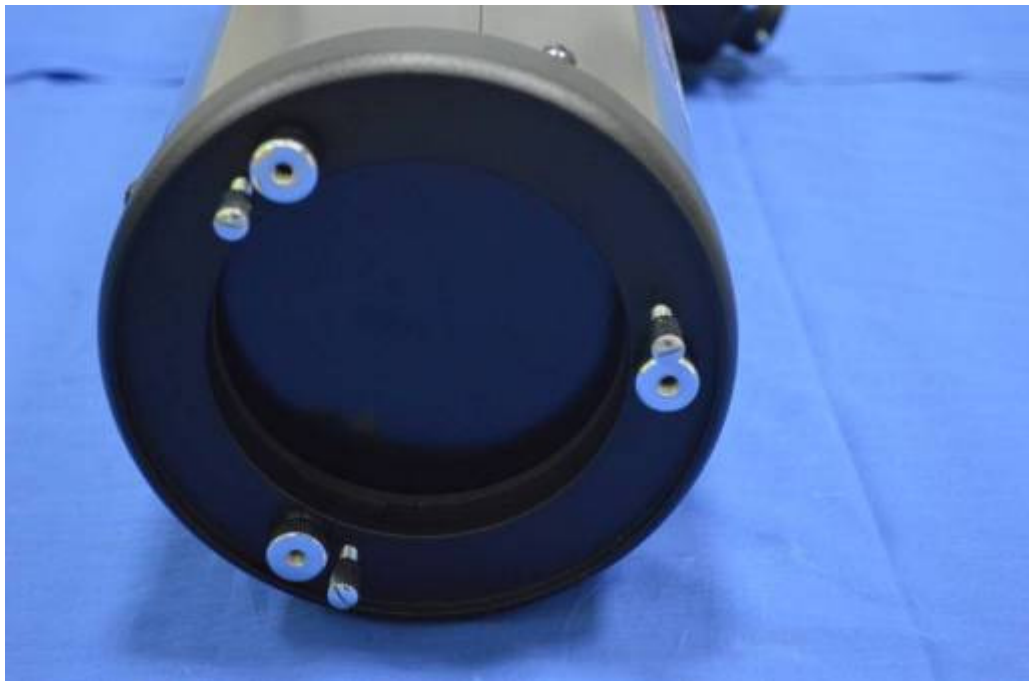



9) EUT Photo



10) EUT Photo





11) EUT Photo



12) EUT Photo





13) EUT Photo



14) EUT Photo

