

# MICRO-GUIDE

## Reticle Eyepiece

– Manual –

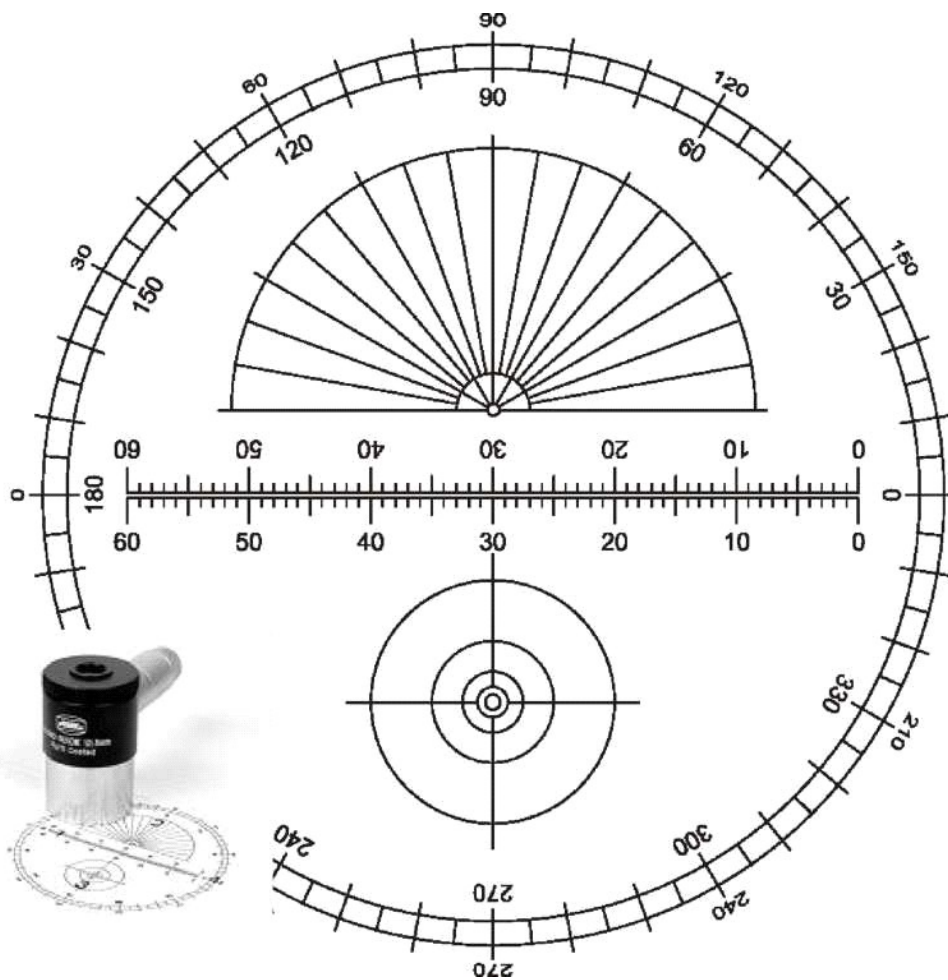

© 2018 Micro-Guide system design by Peter Stättmayer Munich and





The Micro Guide eyepiece is like four eyepieces in one. With four separate scales on one reticle you can guide deep sky astrophotos, measure the angular separation of double stars, determine the periodic error of your drive system, or measure the position angle of a comet's tail. The laser-etched reticle offers sharp lines for the best possible definition. And, the variable brightness illuminator makes it easy to use even on faint stars. The diagram below illustrates the various scales of the Micro Guide eyepiece.

### The four scales of the Micro Guide eyepiece are

- the linear scale (1),
- semicircular position angle scale (2),
- concentric guiding circles (3),
- and the large circular scale (4)

The function of each scale is described separately. Math is included so advanced observers can use the Micro Guide to its fullest potential. But don't think you need to understand the math to use the eyepiece. The detailed description in the text is all you need.

Furthermore, don't think you need to use all the functions of the Micro Guide eyepiece right away. The ones you use most will depend on the type of observing you prefer. And last, don't think you must use a specific reticle as described in the instructions. The use of each scale is limited only by your imagination.

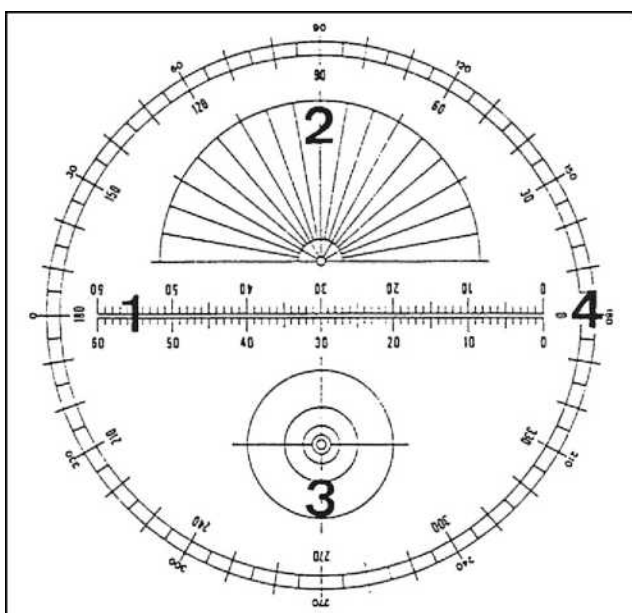

**Linear Scale:** This scale is exactly 6 mm long and has 60 divisions, so that the distance between the marks on the scale is 100  $\mu\text{m}$ . The distance between the long parallel lines is 50  $\mu\text{m}$  center-to-center, so the free space between them is about 35  $\mu\text{m}$ .

**Concentric Circles:** These have diameters of 125, 250, 500, 1000, and 2000  $\mu\text{m}$ .

**Position Angle Scale:** The diameter of the small central circle is 100  $\mu\text{m}$ . For clarity, no numbers are etched by this scale, but they can be read without difficulty from the neighboring numbers on the circular scale.

**Large Circular Scale:** The values of the angles are assigned according to the conventional astronomical definition of position angle. The large (inner) numbers are intended for use with an astronomical (inverting) telescope, while the smaller (outer) numbers apply if the telescope is used with a star diagonal. Unless otherwise stated, all angular values refer to the large numbers of this scale.

### Background Information about Angles

As seen from the Earth, celestial bodies subtend angles which depend on their actual distances and sizes. The most frequently used unit of angular measurement in astronomy is the degree. One degree ( $1^\circ$ ) is  $\frac{1}{360}$  of a circle. Like hours (of time and right ascension), degrees are subdivided into 60 minutes ( $60'$ ), each of which has 60 seconds ( $60''$ ). To distinguish them from units of time, the divisions of a degree are called arc minutes and arc seconds. An arc second is approximately the angle subtended by a golf ball at a distance of 10 km (6 miles)!

$$1^h = 60^m = 3600^s$$

$$1^\circ = 60' = 3600''$$

Here are the angular sizes of a few typical astronomical objects:

The constellation Orion .....	$25^\circ \times 35^\circ$
Large Magellanic Cloud .....	$8^\circ \times 8^\circ$
Andromeda Galaxy M31 .....	$2.7^\circ \times 0.6^\circ$
Great Nebula in Orion M42/43 ...	$1.1^\circ \times 1^\circ$
Sun and Moon .....	$30'$
Ring Nebula M57 .....	$83'' \times 60''$
Mars .....	$15''$
Neptune .....	$2''$
Pluto .....	$0.1''$

Angles can also be measured in terms of circular arc length, using a unit called the radian. The central angle  $\alpha$  (in radians) of a circle is given by its subtended arc length  $b$  divided by the circle's radius  $r$ :  $\alpha = b/r$ .

One radian is the central angle of a circle whose arc length is equal to the circle's radius. It has a value of 57,3° or 3438', or 206265"

For the small angles which would be measured with the Micro Guide, the arc can be treated as a straight line. Then the size of the measured angle  $\alpha$  in arc seconds is related to the size  $b$  and distance  $r$  of an object by the formula:

$$\alpha = 206265'' \times (b / r)$$

### Examples:

At an average opposition distance of 588 million km, Jupiter (equatorial diameter 142800 km) has an angular diameter of:

$$\alpha = 206265'' \times (142800\text{km} / 588000000\text{km}) = 50.1''$$

One millimeter in the focal plane of a telescope with 2000 mm focal length corresponds to an angle of:

$$\alpha = 206265'' (1\text{mm} / 2000\text{mm}) = 103'' = 1.72'$$

## Measuring Angles

To begin, the linear scale must be calibrated. If the telescope's focal length  $f$  in mm is known exactly, the distance in arc seconds between scale divisions  $SD$  is given by:

$$SD = 20626 / f$$

### Example:

For a telescope with focal length 2000 mm:

$$SD = 20626 / 2000 = 10,3''$$

If the telescope's focal length is not known exactly (Values given by the producers of commercial instruments are usually averages.), the angular separation of the scale divisions can be determined by timing the passage of a star along the scale while the telescope's drive is turned off.

To perform this measurement, orient the linear scale so that it is parallel to the celestial equator. This is done by positioning a star (preferably one at low declination, since they move faster) in the middle of the field of view, between the lines at mark 30, and turning the drive off. The star will now drift toward the edge of the field. When the star reaches the circular scale, turn the drive back on and rotate the eyepiece so that the star is on the 180° mark. This brings the scale into good east-west alignment. Let the star drift along the scale once more and, if necessary, make fine adjustments until the star drifts without deviating from the scale. Then position the star at the 0° mark on the circular scale, turn off the drive, and time the star's drift from 0 to 60 along the linear scale. For higher accuracy, perform this measurement several times and take the average of the timings.

The angular separation of the scale divisions  $SD$  is given by the following formula, where  $t$  is the time in seconds taken by the star to drift from 0 to 60 on the scale and  $\delta$  is the star's declination in degrees.

$$SD = (t \times \cos \delta) / 4$$

### Example:

It takes 83.05 seconds for a star at 20° declination to drift from 0 to 60 on the scale. The formula yields a separation between scale divisions of:

$$SD = (83.05'' \times \cos 20) / 4 = 19.5''$$

This method can also be used to accurately determine a telescope's focal length. The focal length  $f$  is found by using the same values of  $t$  and  $\delta$  as above in the following formula:

$$f = 82506 / (t \times \cos \delta)$$

In the above example, the telescope's focal length is found to be:

$$f = 82506 / (83.03 \times \cos 20^\circ) = 1057 \text{ mm}$$

If you use a Barlow or telecompressor lens, you should NOT simply multiply or divide the derived value of  $SD$  by the amplification factor of the lens, since that may depend on the position of the eyepiece and may not exactly match the quantity given by the manufacturer. For telescopes which are focused by moving the primary mirror (most SCT's), the effective focal length with a star diagonal will be different from that for direct viewing. You should use the procedure

described above to find the effective focal length and corresponding SD of any optical configuration you use. For example, tests of Micro Guide with a C8 showed a focal length of 2140 mm (SD = 9,64") with a diagonal prism, while the focal length without the prism was found to be 1884 mm (SD = 10,95").

Once the scale is calibrated, Micro Guide can be used for direct measurement of angular distances and sizes, for example sizes of sunspots and lunar features, height of prominences, or separation of double stars. When seeing permits, such measurements can be estimated to an accuracy of about 1/5 of a scale division, 20  $\mu\text{m}$  at the focal plane or 2" for a focal length of 2000 mm. If an object's distance is known, the measured angular size and known focal length can be used to determine the object's actual size and, conversely, if the true size of an object is known, its distance can be found. This naturally applies to terrestrial observations as well.

Distances and sizes are determined with the following formulas:

$$b = r (a / f), \text{ bzw } r = b (f / a)$$

where:

$b$  : Size of object

$r$  : Distance to object

$f$  : Focal length of telescope

$a$  : Image size in mm (1 SD = 0.1 mm)

### Examples:

The crater Copernicus appears 0.5 mm (5 SD) across when viewed through a telescope of 2000 mm focal length. According to the almanac, the moon's distance at the time of the observation is 377000 km. Then Copernicus' true size is:

$$b = 377000 \text{ km} \times (0.5 \text{ mm} / 2000 \text{ mm}) = 94 \text{ km}$$

A post known to be one meter tall appears to be 2.5 mm (25 SD) tall when observed through a telescope of 760 mm focal length. The distance to the post is then:

$$r = 1 \text{ m} \times (760 \text{ mm} / 2,5 \text{ mm}) = 304 \text{ m}$$

Other applications of the Micro Guide eyepiece include measuring the periodic error of a clock drive or the effects of atmospheric seeing.

## Orientation and Use of the Position Angle Scale

Position angles (PA) are used to describe the direction from one object to another or to a certain point on the celestial sphere. In astronomy, they are measured from north (0°) through east (90°), south (180°) and west (270°). Two stars with the same right ascension have PA of 0° or 180° and two stars with identical declination have PA of 90° or 270°, depending on which star is used as the reference point; for double stars, this is the brighter component.

Before measuring position angles, the scale must be oriented with the celestial coordinate system. Bring a star to the center of the field of view between the lines of the linear scale at mark 30. Then turn off the drive (or use the slow motion to move the telescope toward the east) until the star reaches the circular scale. Now rotate the eyepiece so that the star lies on the 270° mark of the circular scale. Since many eyepiece holders don't hold an eyepiece perfectly centered (and the reticle of the Micro Guide may not have been perfectly centered during manufacture), the adjustment of the eyepiece should be checked by setting the star on the 90° mark of the circular scale and letting it drift across the field of view. If the star reaches the other side of the scale at the 270° mark, then the eyepiece is correctly positioned; otherwise, fine adjustments should be made until it is.

Position angles of objects which extend over the entire field of the eyepiece (e.g. comet tails) can be measured by positioning the reference point (the comet's nucleus) in the center of the Micro Guide's field and reading the position angle where the object intersects the circular scale. For smaller objects or distances, the smaller (semicircular) scale should be used; the reference point for the measurement is then positioned in the small circle at the center of the scale. Depending on an object's orientation, it might be necessary to change the measured angle by adding or subtracting 180° if – for example – the fainter component of a double star is used as the reference point. As mentioned in the description of the circular scale, the big numbers apply for astronomical (inverting) telescopes and the smaller numbers apply for telescopes used with a star diagonal.

If you use a German equatorial mounting, the Micro Guide must be turned by 180° if the telescope is turned around!

## Guiding with Micro Guide

No telescope drive system – amateur or professional – is accurate enough to follow the stars with arc second precision during the long exposures needed for deep-sky photography. At long focal lengths, the resulting image movement will substantially exceed the resolution of the film<sup>1</sup> if the telescope is not guided during the exposure.

To assist in the guiding of long-exposure photographs, several of the scales on the Micro Guide reticle can be used: the guide star can be positioned on a cross, in the center of a circle, or between any two marks on the linear scale.

The latter method is especially sensitive if the linear scale has been oriented with the technique described above for calibration of the scale using a star's drift time. The guide star should be positioned between the two lines at exactly the position of an imaginary line connecting two scale divisions. Even extremely small tracking errors will be easily noticeable. Field tests of Micro Guide have shown that it is possible to record (faint) stellar images as small as 20  $\mu\text{m}$  on the film even when the exposure is made at the same focal length as that of the guide scope – very good performance. If even smaller images are desired (usually possible only with very high-resolution films and – by average seeing – with relatively short focal lengths), then a guide scope of correspondingly longer focal length should be used.

Too bright a guide star should not be used. Fainter – though still easily visible – stars allow more accurate guiding. The relatively large number of illuminated lines on the Micro Guide's reticle does not restrict the limiting magnitude of potential guide stars. You can use just as faint a guide star with Micro Guide as with a typical single-crosshair illuminated guiding eyepiece.

For photography at focal lengths which are small relative to that of the guide scope (piggyback photography), small deviations in the guide star's position can be tolerated, making the task of guiding easier. The concentric circles on the Micro Guide reticle are provided for this purpose. Depending on the guiding focal length and the film resolution, the size of the circle in which the guide star should stay in order to form a given image size can be calculated for any focal length. For example, if the guide scope has 10 times the focal length of the camera and a resolution of 25  $\mu\text{m}$  is desired, then the guide star may move a maximum of 250  $\mu\text{m}$  in the guide scope's focal plane. This is exactly the diameter of the second tolerance circle on the Micro Guide reticle. The exposure should be started with the guide star in the second smallest tolerance circle; during the exposure, the guide star should be checked occasionally to confirm that it stays within the tolerance circle.

In general, the maximum useful camera focal length  $f_C$  for a given stellar image size  $d_s$ , guide scope focal length  $f_G$  and tolerance circle diameter  $d_T$  is given by the formula below:

$$f_C = f_G \times (d_s / d_T)$$

### Example:

For a guide scope of 2000 mm focal length and stellar image size of 20  $\mu\text{m}$ , the table below displays camera focal lengths that can be used with the different sizes of tolerance circle.

Tolerance circle	1 <sup>st</sup> circle	2 <sup>nd</sup> circle	3 <sup>rd</sup> circle	4 <sup>th</sup> circle	5 <sup>th</sup> circle
camera focal length	320 mm	160 mm	80 mm	40 mm	20 mm

## Indirect Guiding

Long exposures of moving objects such as comets require that the telescope be guided on the comet if its movement during the exposure exceeds the resolution of the film being used.

If the telescope is driven at the sidereal rate, the length  $L$  in mm of the comet's track on the film is given by:

$$L = v \times t \times f / 206265$$

where:

$v$  = Angular speed in arc seconds per minute of time,

$t$  = Exposure duration in minutes,

$f$  = Focal length of camera in mm

<sup>1</sup> The resolution of an emulsion is determined by a variety of factors, including grain size, contrast (and method of development), diffusion, etc. Given good optics, sharp focus, and precise guiding, a resolution of 20  $\mu\text{m}$  can be attained in stellar photography with high-resolution films; this resolution is the image diameter of the faintest stars recorded in an exposure and can generally be regarded as very sharp. With Kodak's very fine-grained Technical Pan film (recommended for long exposures only when hypered), stellar image sizes as small as 12  $\mu\text{m}$  can be reached. If this film is used with seeing of 2" (relatively good), the sharpness is limited by the steadiness of the atmosphere at focal lengths above 1250 mm.

**Example:**

In May 1990, Comet Austin moves with a speed of about 10" per minute with respect to the fixed stars. If a 30-minute exposure is made with a telescope of 1000 mm focal length driven at the sidereal rate, the length of the comet's trail on the film will be:

$$L = (10 \times 30 \times 1000) / 206265 = 1,45 \text{ mm}$$

If the telescope is driven at the sidereal rate, the comet's image will be severely blurred and the darkening on the negative will be much weaker than on an exposure made by guiding on the comet.

The following formula can be used to calculate the longest possible sidereally driven exposure  $t_{max}$  in minutes for which the comet's movement on the film is less than the film's resolution  $A$ :

$$t_{max} = 206265 \times A / v \times f$$

where:

$v$  and  $f$  same as in the above example, and

$A$  = film resolution in mm

Using the data from the previous example with a film resolution of 20  $\mu\text{m}$  yields a maximum exposure length of only about half a minute!

For longer exposures, the telescope must be guided on the comet's motion if the comet's image is to be recorded sharply. If the comet's nucleus is bright enough, it can be used for guiding by setting one of the Micro Guide's scales on it and making occasional drive corrections just as for an ordinary guide star. Unfortunately, even most bright comets have nuclei too faint to use for guiding. Sometimes a comet's coma has a central condensation strong and bright enough to use for guiding. But often, this is not the case either and the only alternative is "indirect guiding", for which the Micro Guide is admirably suited. This method is also applicable to photography of very faint minor planets, whose rapid movement would otherwise prevent sufficient darkening of the negative to form an image.

Indirect guiding is performed by calculating the apparent angular speed and direction of the comet from its orbital elements and using these values to orient the linear scale so that a guide star can be moved opposite the comet's motion along the scale by adjusting the declination and right ascension controls. This will cause the telescope to follow the comet.

If no computer program is available to generate the required data, it is advisable to consistently use the same procedure (such as the one suggested here) to calculate the speed and direction angle. (The direction angle describes the comet's motion relative to celestial north and is measured in the same way as position angle.)

First, the R.A. and Dec. from the orbital elements must be converted to decimal hours and degrees. In the following analysis, these decimal values will be designated  $\alpha$  and  $\delta$ ; the values  $\alpha_1$  and  $\delta_1$  represent values at an earlier time;  $\alpha_2$  and  $\delta_2$  are the values at a later time. (This definition is important since the signs of these quantities are used later to determine the direction angle.) The changes in R.A. ( $\Delta\alpha = \alpha_2 - \alpha_1$ ) and Dec. ( $\Delta\delta = \delta_2 - \delta_1$ ) over an interval of  $d$  days must be calculated.

From these values, the angular speed  $v$  in arc seconds per minute of time can be calculated as follows:

For R.A. :  $v_\alpha = (37,5 \times \Delta\alpha \times \cos \bar{\delta}) / d$ , with  $\bar{\delta} = (\delta_1 + \delta_2) / 2$  ;

For Dec.:  $v_\delta = (2,5 \times \Delta\delta) / d$

From these values the resultant angular speed  $v_{res}$  is given by:  $v_{ges} = \sqrt{v_\alpha^2 + v_\delta^2}$

And the angle  $\beta$ :  $\beta = \arctan v_\alpha / v_\delta$

is used to find the direction angle DA:

$$DA = \begin{cases} \beta & \text{for } \Delta\alpha > 0 \text{ and } \Delta\delta > 0 \\ 180^\circ + \beta & \text{for } \Delta\alpha > 0 \text{ and } \Delta\delta < 0 \\ 180^\circ + \beta & \text{for } \Delta\alpha < 0 \text{ and } \Delta\delta < 0 \\ 180^\circ + \beta & \text{for } \Delta\alpha < 0 \text{ and } \Delta\delta > 0 \end{cases}$$

(Note the sign of angle  $\beta$ ! If  $\Delta\alpha > 0$  and  $\Delta\delta < 0$  or  $\Delta\alpha < 0$  and  $\Delta\delta > 0$  then  $\beta$  is negative and must be subtracted from  $180^\circ$  or  $360^\circ$ , respectively.)



Once the angular speed has been calculated, it can be divided by the angular separation of the divisions in the linear scale to find the speed  $v_{SD}$  in divisions per minute at which the guide star must be moved along the scale. The reciprocal of this velocity is the step time  $t_{SD}$  in minutes needed for the star to move through one division along the scale:

$$v_{SD} = v_{res} / SD = (v_{res} \times f) / 20626 ,$$

$$t_{SD} = SD / v_{res} = 20626 / (v_{res} \times f)$$

The values of  $v_{SD}$  (or  $t_{SD}$ ) and  $DA$  are used in the following way for indirect guiding:

1. The eyepiece must be oriented as described for measurement of position angles.
2. Without turning the eyepiece, use the slow motion controls to position the guide star on the circular scale at the value corresponding to the calculated direction angle  $DA$ . Remember to use the small numbers of the circular scale if you are working with a star diagonal.
3. Turn the eyepiece so that the guide star is on the big  $0^\circ$  mark (also if you are using a star diagonal). The linear scale is now oriented in the direction of the comet's movement.
4. Place the guide star on the 0 mark of the linear scale and begin the exposure. The star should be moved along the scale at the calculated speed  $v_{SD}$  by making small adjustments with the R.A. and Dec. controls. (Steps 2 and 3 are diagrammed in the figures on page 11.)

It is not necessary to move the guide star continuously and with exactly the calculated speed. For example, if the guide scope has twice the focal length of the camera, then it is enough to move the star in steps of half a division in every time interval (in this case,  $t_{SD}/2$ ). This will result in resolution of  $25 \mu\text{m}$  on the film. If this step length is used with a guiding focal length four times that of the camera, then the guiding accuracy will be so good that very sharp images will be formed even on fine-grained films such as Technical Pan.

If the step time ( $t_{SD}$ ) is several minutes, the time for the next adjustment of the guide star can be comfortably read from a stopwatch. For this purpose, create a table (as in the table below) of the times at which the guide star's position must be adjusted. But if the step time is too short, it becomes difficult to keep track- of the guide star, stopwatch, and table simultaneously. In this case, it is advisable to use a timer which will give a signal when it is time to adjust the star's position. A programmable calculator with a beep-function can be used for this purpose.

Here are two example calculations of the parameters for indirect guiding:

Example 1:

Coordinates of Comet Austin on

April 20, 1990: R.A. =  $1^{\text{h}} 01^{\text{m}} 37^{\text{s}}$ , Dec. =  $+34^\circ 31' 39''$

April 22, 1990: R.A. =  $0^{\text{h}} 52^{\text{m}} 13^{\text{s}}$ , Dec. =  $+35^\circ 14' 19''$

$$\alpha_1 = 1.0269^{\text{h}}$$

$$\alpha_2 = 0.8703^{\text{h}}$$

$$\Delta\alpha = 0.1566^{\text{h}}$$

$$\delta_1 = +34.5275^\circ$$

$$\delta_2 = +35.2386^\circ$$

$$\Delta\delta = +0.7111^\circ$$

$$v_\alpha = [37.5 \times (-0.1566^{\text{h}}) \times \cos(34.9^\circ)] / 2 = -2.41'' \text{ per minute}$$

$$v_\delta = (2.5 \times 0.7111^\circ) / 2 = +0.89'' \text{ per minute}$$

$$v_{res} = \sqrt{(-2.41'')^2 + 0.89''^2} = 2.57'' \text{ per minute}$$

$$\beta = \arctan 2.41'' / 0.89'' = -70^\circ$$

$$DA = 360^\circ + \beta = 360^\circ - 70^\circ = 290^\circ, \text{ since } \Delta\alpha < 0 \text{ and } \Delta\delta > 0.$$

With a guiding focal length of 2000 mm

$$v_{SD} = (2.57'' \times 2000) / 20626 = 0.25 \text{ scale divisions per minute}$$

$$t_{SD} = 20626 / (2.57'' \times 2000) = 4 \text{ minutes per division}$$

Example 2:

Coordinates of Comet Austin on

May 20, 1990: R.A. = 21<sup>h</sup> 14<sup>m</sup> 00<sup>s</sup>, Dec. = +18° 01' 49"

May 22, 1990: R.A. = 20<sup>h</sup> 43<sup>m</sup> 55<sup>s</sup>, Dec. = +12° 45' 44"

$$\alpha_1 = 21.2333^h$$

$$\alpha_2 = 20.7319^h$$

$$\Delta\alpha = -0.5014^h$$

$$\delta_1 = +18.0303^\circ$$

$$\delta_2 = +12.7622^\circ$$

$$\Delta\delta = -5.2681^\circ$$

$$v_\alpha = [37.5 \times (-0.5014^h) \times \cos(15.4^\circ)] / 2 = -9.06'' \text{ per minute}$$

$$v_\delta = [2.5 \times (-5.2681^\circ)] / 2 = +6.59'' \text{ per minute}$$

$$v_{\text{res}} = \sqrt{(-9.06'')^2 + (+6.59'')^2} = 11.20'' \text{ per minute}$$

$$\beta = \arctan(-9.06'') / (+6.59'') = +54^\circ$$

$$DA = 180^\circ + \beta = 180^\circ + 54^\circ = 234^\circ, \text{ since } \Delta\alpha \text{ and } \Delta\delta \text{ are both } < 0.$$

With a guiding focal length of 2000 mm

$$v_{\text{SD}} = (11.20'' \times 2000) / 20626 = 1.09 \text{ scale divisions per minute}$$

$$t_{\text{SD}} = 20626 / (11.20'' \times 2000) = 0.92 \text{ minutes per division}$$

It should be noted that the calculated speed and direction are not those on the dates for which coordinates were given, but on the date between; in Example 1, the calculation is for a photograph to be taken on April 21. It is helpful to write the necessary data in a table like the one below. Better still, write a small computer program to produce the data.

<u>Date</u>	<u>R.A.</u>	<u>Dec.</u>	<u>v<sub>res</sub></u>	<u>A</u>	<u>v<sub>SD</sub></u>	<u>t<sub>SD</sub></u>
April 20, 1990	1 <sup>h</sup> 01 <sup>m</sup> 37 <sup>s</sup>	+34° 31' 39"	...			
April 21, 1990	0 <sup>h</sup> 56 <sup>m</sup> 57 <sup>s</sup>	+34° 54' 56"	2.57"	290°	0.25	4
April 22, 1990	0 <sup>h</sup> 52 <sup>m</sup> 13 <sup>s</sup>	+35° 14' 19"	...	...	...	...
...	...	...	...	...	...	...
...	...	...	...	...	...	...
...	...	...	...	...	...	...
May 20, 1990	21 <sup>h</sup> 14 <sup>m</sup> 00 <sup>s</sup>	+18° 01' 49"	...	...	...	...
May 21, 1990	20 <sup>h</sup> 59 <sup>m</sup> 15 <sup>s</sup>	+15° 30' 40"	11.2"	234°	1.09	0.92
May 22, 1990	20 <sup>h</sup> 43 <sup>m</sup> 55 <sup>s</sup>	+12° 45' 44"	...	...	...	...

The table below shows the times at which adjustments of the guide star must be made during the exposure described in Example 2 for a guiding focal length of 2000 mm.

scale divisions	0	0.5	1	1.5	2	2.5	3	...
time	0	27 <sup>s</sup>	55 <sup>s</sup>	1 <sup>m</sup> 22 <sup>s</sup>	1 <sup>m</sup> 50 <sup>s</sup>	2 <sup>m</sup> 18 <sup>s</sup>	2 <sup>m</sup> 45 <sup>s</sup>	...

The diagrams below show how the MICRO-GUIDE should be positioned for the direction angle of  $234^\circ$  according to the steps of Example 2 above.

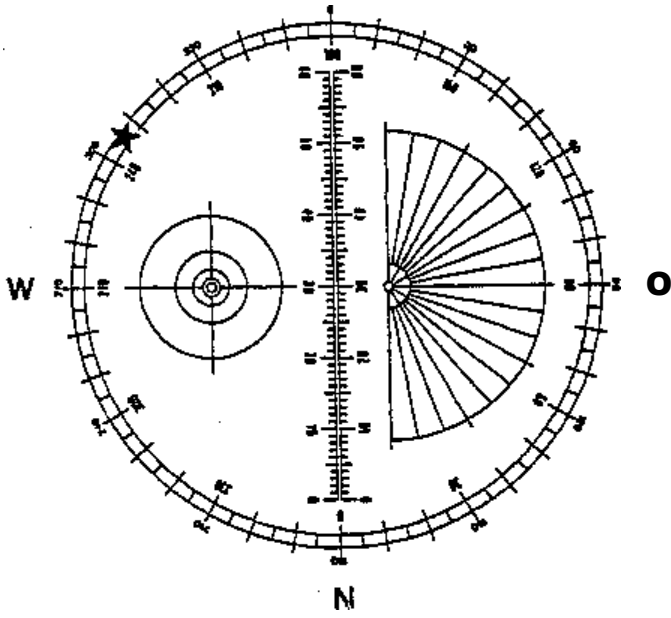

step 2

without stardiagonal

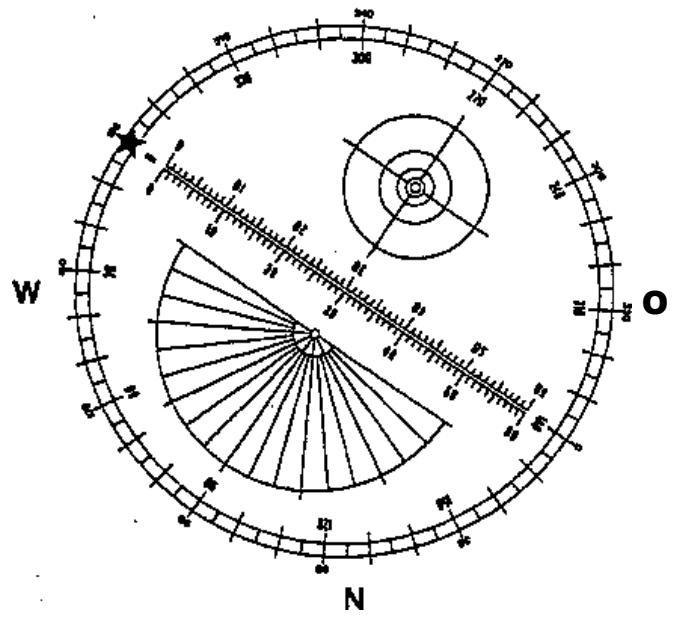

step 3

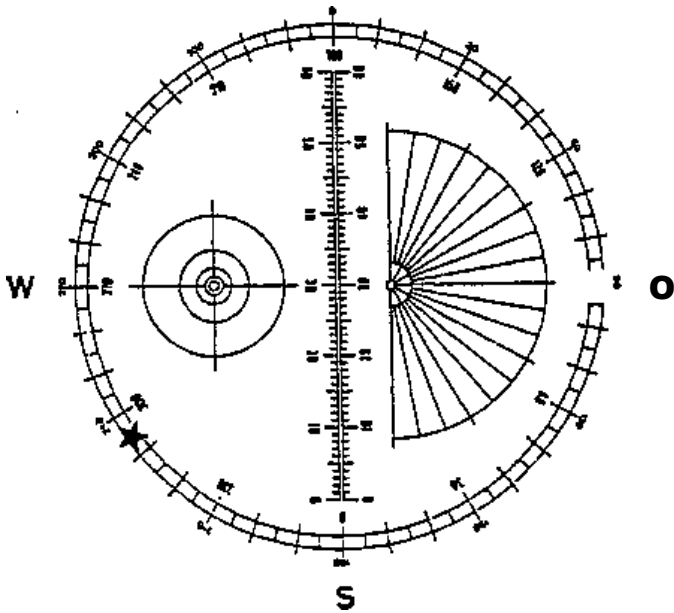

step 2

with stardiagonal

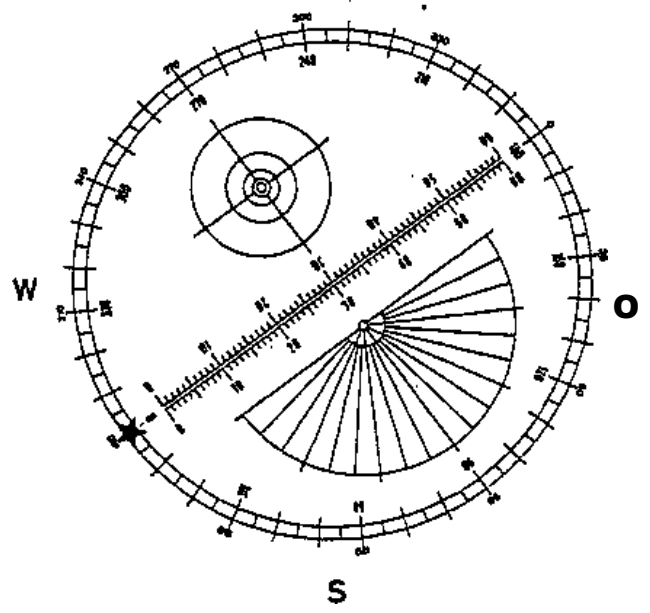

step 3

## Spectrographic Application of Micro Guide

If a point source of light is dispersed by a grating or prism, a (theoretically) dimensionless linear spectrum will be formed. In order for spectral features such as absorption lines to be discernible in a photograph, the spectrum must be broadened into a band. This can be accomplished by moving the telescope back and forth through a certain angle during the exposure in a direction perpendicular to the spectral dispersion. The prism or grating should be positioned so that the spectra are dispersed north-south. During the exposure, the right ascension slow motion can be used to move the telescope back and forth in the east-west direction.

Micro Guide is also well-suited to this kind of exposure. The Micro Guide should be set in the guide scope so that the linear scale is oriented east-west and the guide star positioned between the lines at mark 0; the exposure can then be started. The right ascension slow motion should be used to move the guide star through a certain number of scale divisions and then back to the starting point; this procedure is repeated throughout the exposure. One must be ready to correct for declination changes of the guide scope, possibly caused by a slightly misaligned mounting or by refraction effects; such changes can broaden and blur the absorption lines. With the guide star placed between the parallel lines of the linear scale, deviations in declination can be easily recognized.

For easily recognizable absorption lines, a spectral width of one millimeter on the film is quite sufficient. If the guiding focal length is equal to that of the camera, then a back-and-forth motion of 10 scale divisions is needed; for other ratios of focal length, a correspondingly larger or smaller oscillation is needed. If the camera is capable of multiple exposures, then several spectra can be recorded on one negative (for example, the same star with different exposure times or the spectra of several different stars) if the first exposure is made by oscillation between the 0 and 10 marks and the second between the 20 and 30 marks, etc.

This manual and all texts are protected by international copyright laws. No part of this document or its wording shall be copied by third parties. Any reproduction, duplication, electronic copying, transfer into other media or into the Internet or intranet, or other means of publication - even in part and regardless of the layout - are explicitly prohibited and will be prosecuted by law. We reserve the right for errors and technical changes.

© 2018 by Baader Planetarium GmbH, Mammendorf, Germany



**BAADER PLANETARIUM** G  
M  
B  
H  
Zur Sternwarte 4 • D-82291 Mammendorf • Tel. +49 (0) 8145 / 8089-0 • Fax +49 (0) 8145 / 8089-105  
[www.baader-planetarium.com](http://www.baader-planetarium.com) • [kontakt@baader-planetarium.de](mailto:kontakt@baader-planetarium.de) • [www.celestron.de](http://www.celestron.de)